

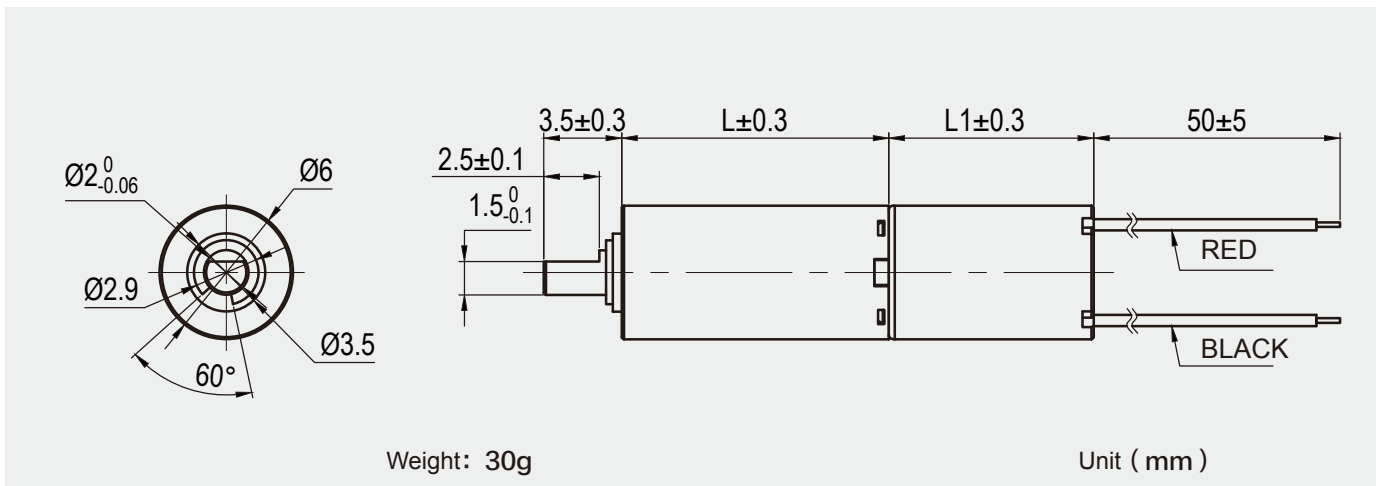

Typical Applications

- Smart Locks: Door Lock, Fingerprint Lock, Express Cabinet Lock, Bike Lock

Outline Dimension



Technical Data

MODEL	VOLTAGE	NO-LOAD		AT MAXIMUM EFFICIENCY				STALL TORQUE			GEAR RATIO	LENGTH OF GEAR BOX(L)	MATCH THE MOTOR	LENGTH OF MOTOR(L1)	
		SPEED	CURRENT	SPEED	CURRENT	TORQUE		OUTPUT	TORQUE	CURRENT					
	V	r/min	A	r/min	A	mN.m	Kg.cm	W	mN.m	Kg.cm	A	mm		mm	
JL-06P610-136	3.7	265	0.032	200	0.1	13	0.13	0.17	55.7	0.57	0.32	136	9.6	-	10

Packing Details

QTY: 400 pcs/ctn Carton Size: 36.5*26.5*25 cm Gross Weight: 15 kg/ctn Net Weight: 14 kg/ctn Unit weight :30g



Typical Applications

- Smart Locks: Door Lock, Fingerprint Lock, Express Cabinet Lock, Bike Lock
- Household Appliances: Hair Curler
- Financial Medical Equipment: 3Doodler ,Projector
- Industrial Equipment: Air Switch
- Intelligent Robot: Mechanical Arm, UAV(Unmanned Aerial Vehicle), Service Robot

Outline Dimension

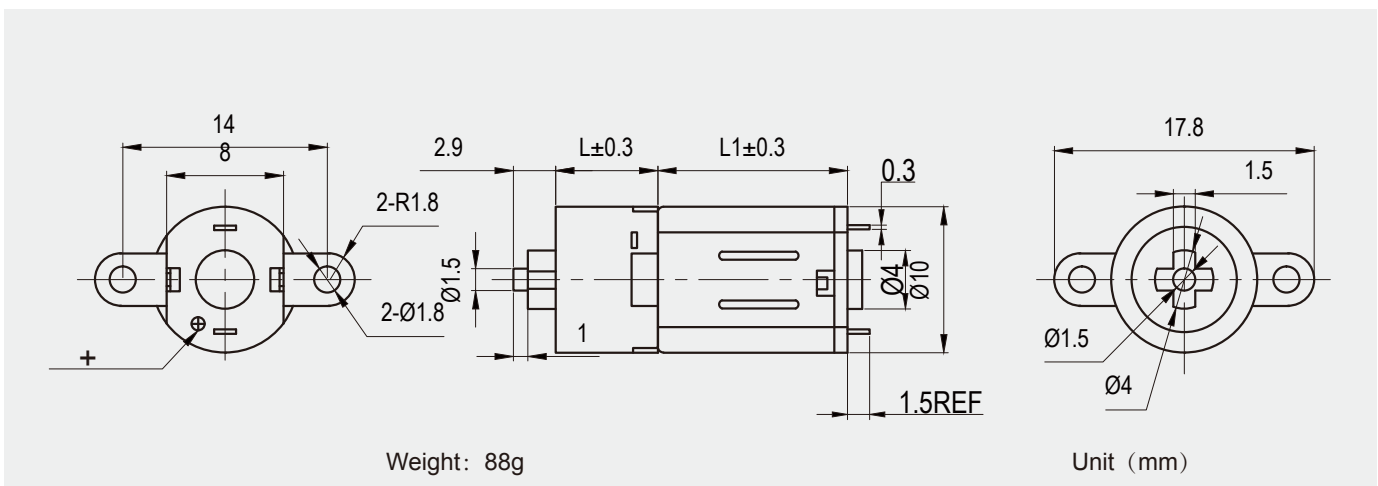

Voltage, rated torque, speed, current, power and shaft size can be customized as requirement.

Technical Data

MODEL	VOLTAGE	NO-LOAD		AT MAXIMUM EFFICIENCY				STALL TORQUE			GEAR RATIO	LENGTH OF GEAR BOX(L)	MATCH THE MOTOR	LENGTH OF MOTOR(L1)	
		SPEED	CURRENT	SPEED	CURRENT	TORQUE	OUTPUT	TORQUE	CURRENT						
	V	r/min	A	r/min	A	mN.m	Kg.cm	W	mN.m	Kg.cm	A		mm		mm
JL-10PM10-171	2	42	0.003	30	0.09	5.2	0.05	0.02	20.5	0.21	0.26	171	7	M10	13

Packing Details

QTY:400 pcs/ctn Carton Size: 36.5*26.5*25 cm Gross Weight: 10.5 kg/ctn Net Weight: 10 kg/ctn Unit weight :9.6g



Typical Applications

- Smart Locks: Door Lock, Fingerprint Lock, Express Cabinet Lock, Bike Lock
- Household Appliances: Hair Curler
- Financial Medical Equipment: 3Doodler ,Projector
- Industrial Equipment: Air Switch
- Intelligent Robot: Mechanical Arm, UAV(Unmanned Aerial Vehicle), Service Robot

Outline Dimension

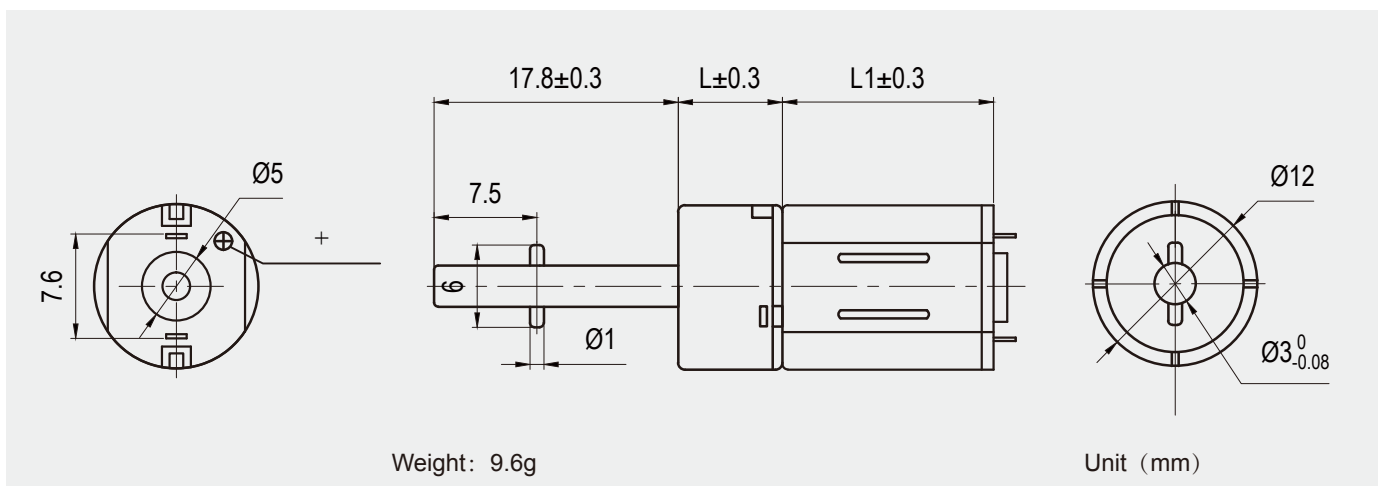

Voltage, rated torque, speed, current, power and shaft size can be customized as requirement.

Technical Data

MODEL	VOLTAGE	NO- LOAD		AT MAXIMUM EFFICIENCY				STALL TORQUE			GEAR RATIO	LENGTH OF GEAR BOX(L)	MATCH THE MOTOR	LENGTH OF MOTOR(L1)	
		SPEED	CURRENT	SPEED	CURRENT	TORQUE		OUTPUT	TORQUE						CURRENT
		r/min	A	r/min	A	mN.m	Kg.cm	W	mN.m	Kg.cm					A
JL-12PN20-125	2	200	0.11	155	0.38	22	0.224	0.6	98	0.999	1.28	125	7.6	N20	15.4

Packing Details

QTY: 1000 pcs/ctn Carton Size: 36.5*26.5*25 cm Gross Weight: 10.5 kg/ctn Net Weight: 10 kg/ctn



Typical Applications

- Smart Locks: Door Lock, Fingerprint Lock, Express Cabinet Lock, Bike Lock
- Household Appliances: Hair Curler
- Financial Medical Equipment: Projector
- Industrial Equipment: Air Switch
- Intelligent Robot: Mechanical Arm, UAV (Unmanned Aerial Vehicle), Service Robot

Outline Dimension

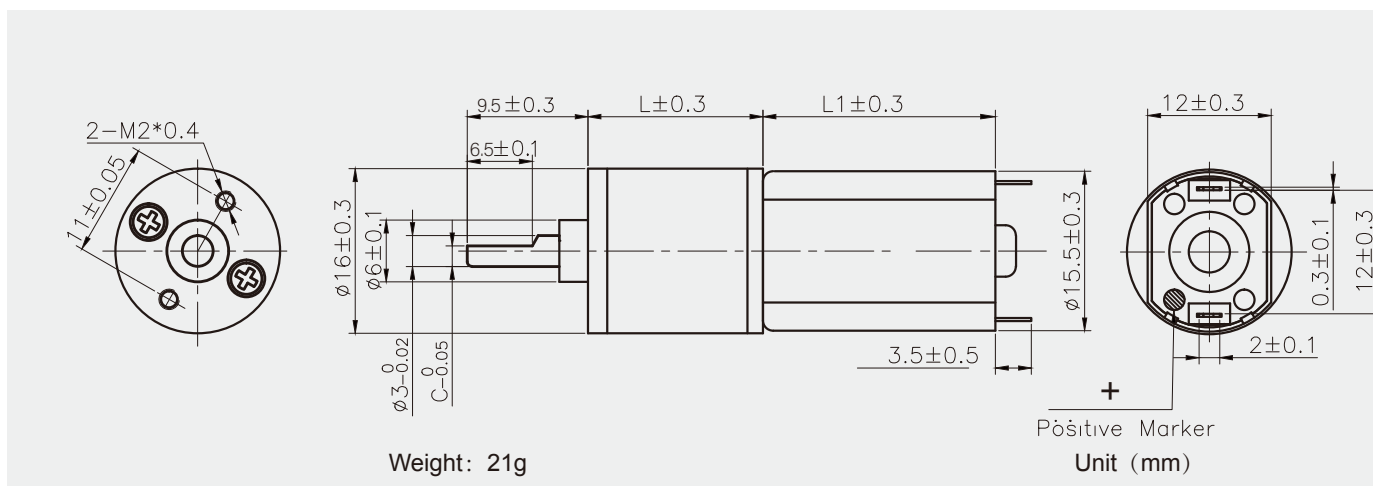

Voltage, rated torque, speed, current, power and shaft size can be customized as requirement.

Technical Data

MODEL	VOLTAGE V	NO-LOAD		AT MAXIMUM EFFICIENCY				STALL TORQUE			GEAR RATIO	LENGTH OF GEAR BOX(L) mm	MATCH THE MOTOR	LENGTH OF MOTOR(L1) mm
		SPEED r/min	CURRENT A	SPEED r/min	CURRENT A	TORQUE		TORQUE	CURRENT					
						mN.m	Kg.cm	mN.m	Kg.cm	A				
JL-16A050-13	12	1858	0.128	1478	0.49	8.0	0.08	16.0	0.16	1.73	13	12.5	JFF/K-050	26.9
JL-16A050-16	12	1509	0.128	1201	0.49	15.5	0.16	31.0	0.32	1.73	16	12.5	JFF/K-050	26.9
JL-16A050-26	12	929	0.128	739	0.49	15.5	0.16	31.0	0.32	1.73	26	12.5	JFF/K-050	26.9
JL-16A050-32	12	755	0.128	600	0.49	16.5	0.17	33.0	0.34	1.73	32	12.5	JFF/K-050	26.9
JL-16A050-37	12	653	0.128	519	0.49	18.5	0.19	37.0	0.38	1.73	37	12.5	JFF/K-050	26.9
JL-16A050-45	12	537	0.128	427	0.49	19.5	0.20	48.8	0.50	1.73	45	12.5	JFF/K-050	26.9
JL-16A050-75	12	322	0.142	256	0.54	20.5	0.21	51.3	0.52	1.73	75	12.5	JFF/K-050	26.9
JL-16A050-91	12	265	0.142	211	0.54	30.5	0.31	76.3	0.78	1.73	91	14	JFF/K-050	26.9
JL-16A050-105	12	230	0.142	183	0.54	32.5	0.33	81.3	0.83	1.73	105	14	JFF/K-050	26.9
JL-16A050-128	12	189	0.142	150	0.54	50.5	0.51	126.3	1.29	1.73	128	14	JFF/K-050	26.9
JL-16A050-148	12	163	0.142	130	0.54	55.6	0.57	139.0	1.42	1.73	148	14	JFF/K-050	26.9
JL-16A050-182	12	133	0.142	106	0.54	70.5	0.72	176.3	1.80	1.73	182	14	JFF/K-050	26.9
JL-16A050-210	12	115	0.160	92	0.61	85.2	0.87	213.0	2.17	1.73	210	15.5	JFF/K-050	26.9
JL-16A050-256	12	94	0.160	75	0.61	90.5	0.92	226.3	2.31	1.73	256	15.5	JFF/K-050	26.9
JL-16D050-362	12	67	0.160	53	0.61	105.8	1.08	264.5	2.70	1.73	362	15.5	JFF/K-050	26.9
JL-16A050-592	12	41	0.160	32	0.61	125.5	1.28	376.5	3.84	1.73	592	17	JFF/K-050	26.9
JL-16A050-723	12	33	0.160	27	0.61	135.6	1.38	406.8	4.15	1.73	723	17	JFF/K-050	26.9
JL-16A050-825	12	29	0.160	23	0.61	145.2	1.48	535.6	5.46	1.73	825	17	JFF/K-050	26.9
JL-16A050-1021	12	24	0.183	19	0.70	205.6	2.10	616.8	6.29	1.73	1021	17	JFF/K-050	26.9

Packing Details

QTY: 400 pcs/ctn Carton Size: 36.5*26.5*24 cm Gross Weight: 9 kg/ctn Net Weight: 8.5 kg/ctn



Typical Applications

- Smart Locks: Door Lock, Fingerprint Lock, Express Cabinet Lock, Bike Lock
- Household Appliances: Hair Curler
- Financial Medical Equipment: Projector
- Industrial Equipment: Air Switch
- Intelligent Robot: Mechanical Arm, UAV(Unmanned Aerial Vehicle), Service Robot

Outline Dimension

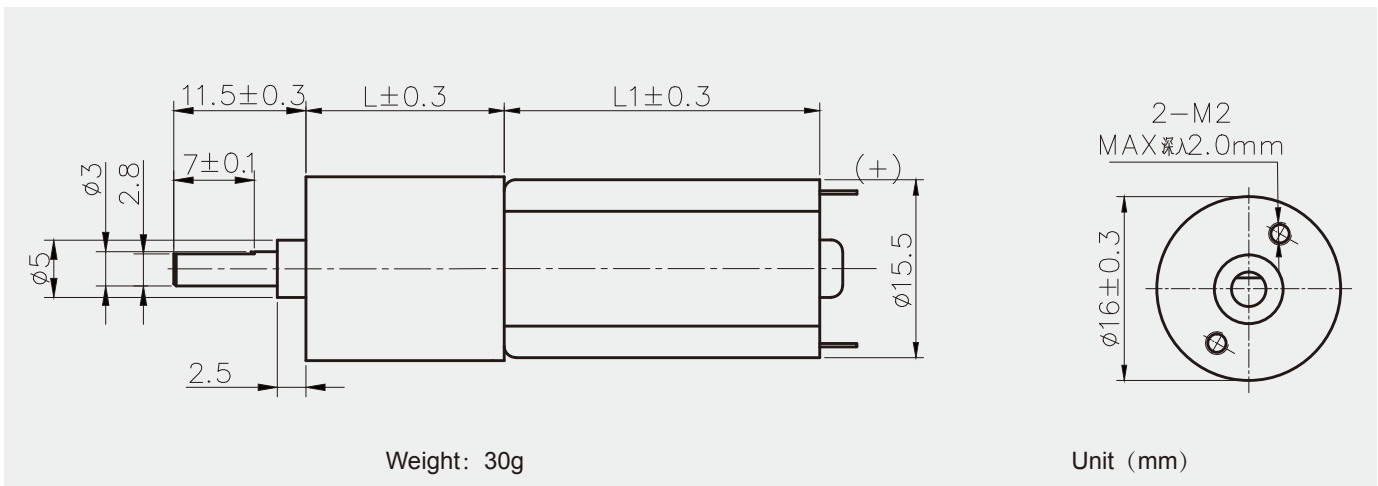

Voltage, rated torque, speed, current, power and shaft size can be customized as requirement.

Technical Data

MODEL	VOLTAGE	NO-LOAD		AT MAXIMUM EFFICIENCY				STALL TORQUE			GEAR RATIO	LENGTH OF GEAR BOX(L)	MATCH THE MOTOR	LENGTH OF MOTOR(L1)
		SPEED	CURRENT	SPEED	CURRENT	TORQUE		TORQUE	CURRENT					
		r/min	A	r/min	A	mN.m	Kg.cm	mN.m	Kg.cm	A				
V	r/min	A	r/min	A	mN.m	Kg.cm	mN.m	Kg.cm	A	mm	mm			
JL-16P050-4	6V	1400	0.09	1130	0.13	1.6	0.02	5.6	0.07	0.65	4	38.4	JFF/K-050	26.9
JL-16P050-16	6V	350	0.09	285	1.13	5.1	0.05	17.9	0.18	0.65	16	41.7	JFF/K-050	26.9
JL-16P050-24	6V	235	0.09	190	0.13	7.5	0.20	26.3	0.70	0.65	24	41.7	JFF/K-050	26.9
JL-16P050-64	6V	90	0.10	75	0.14	13.2	0.14	46.2	0.49	0.65	64	45	JFF/K-050	26.9
JL-16P050-96	6V	55	0.10	50	0.14	19.9	0.20	69.7	0.70	0.65	96	45	JFF/K-050	26.9
JL-16P050-256	6V	22	0.10	18	0.14	39.7	0.41	139.0	1.44	0.65	256	48.3	JFF/K-050	26.9
JL-16P050-384	6V	15	0.10	12	0.14	60.0	0.61	210.0	2.14	0.65	384	48.3	JFF/K-050	26.9
JL-16P050-576	6V	9	0.10	8	0.14	89.0	0.91	311.5	0.46	0.65	576	48.3	JFF/K-050	26.9
JL-16P050-864	6V	6	0.12	5	0.15	134.0	1.37	469.0	4.80	0.65	864	48.3	JFF/K-050	26.9
JL-16P050-1296	6V	4	0.12	3	0.15	196.0	2.00	686.0	7.00	0.65	1296	48.3	JFF/K-050	26.9

Packing Details

QTY: 400 pcs/ctn Carton Size: 36.5*26.5*25 cm Gross Weight: 15 kg/ctn Net Weight: 14 kg/ctn



Typical Applications

- Household Appliances: Electric curtain, Intergrated cooker, Coffee maker, Intelligent closetool, Sweeping robot, Dish-washing Machine, Cooker hood, Electric lock.
- Hair Care: Hair Curler, Massager, Electric Hair Clipper
- Office Equipment: Shredder, Printer, Projector, Counting Machine
- Medical Equipment: Massage chair, Electric trolley, Medical pump, Electric bed, Electric wheelchair
- Industrial Equipment: Water, electrical and gas valve, Air switch, Pump, Automatic door, Automatic lubrication equipment.
- Business Equipment: Vending machines, Parking locks, ATM machines, Stage lights.
- Intelligent Robot: Mechanical Arm, UAV (Unmanned Aerial Vehicle), Service Robot

Outline Dimension

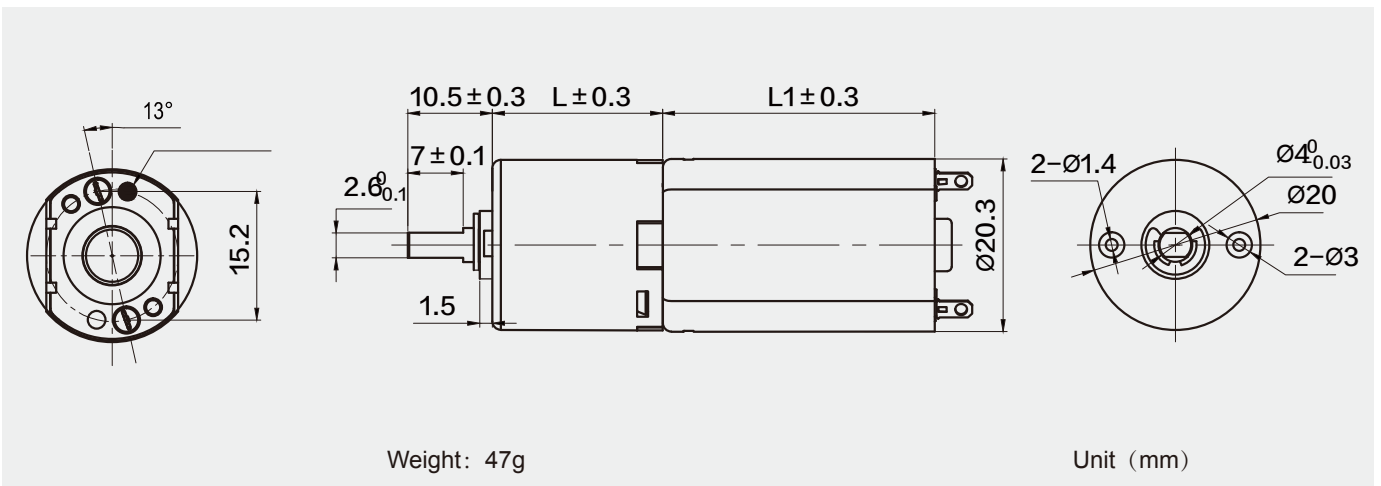

Voltage, rated torque, speed, current, power and shaft size can be customized as requirement.

Technical Data

MODEL	VOLTAGE	NO-LOAD		AT MAXIMUM EFFICIENCY				STALL TORQUE			GEAR RATIO	LENGTH OF GEAR BOX(L)	MATCH THE MOTOR	LENGTH OF MOTOR(L1)	
		SPEED	CURRENT	SPEED	CURRENT	TORQUE		OUTPUT	TORQUE	CURRENT					
	V	r/min	A	r/min	A	mN.m	Kg.cm	W	mN.m	Kg.cm					A
JL-20P180-109	12	100	0.185	79.5	0.42	176.5	1.8	1.47	931.4	9.5	1.8	109	20	FF-180	26.8

Packing Details

QTY: 225 pcs/ctn Carton Size: 41*31*27.8 cm Gross Weight: 11.5 kg/ctn Net Weight: 10.5 kg/ctn



Typical Applications

- Household Appliances: Electric curtain, Intergrated cooker, Coffee maker, Intelligent closetool, Sweeping robot, Dish-washing Machine, Cooker hood, Electric lock.
- Hair Care: Hair Curler, Massager, Electric Hair Clipper
- Office Equipment: Shredder, Printer, Projector, Counting Machine
- Medical Equipment: Massage chair, Electric trolley, Medical pump, Electric bed, Electric wheelchair
- Industrial Equipment: Water, electrical and gas valve, Air switch, Pump, Automatic door, Automatic lubrication equipment.
- Business Equipment: Vending machines, Parking locks, ATM machines, Stage lights.
- Intelligent Robot: Mechanical Arm, UAV (Unmanned Aerial Vehicle), Service Robot

Outline Dimension

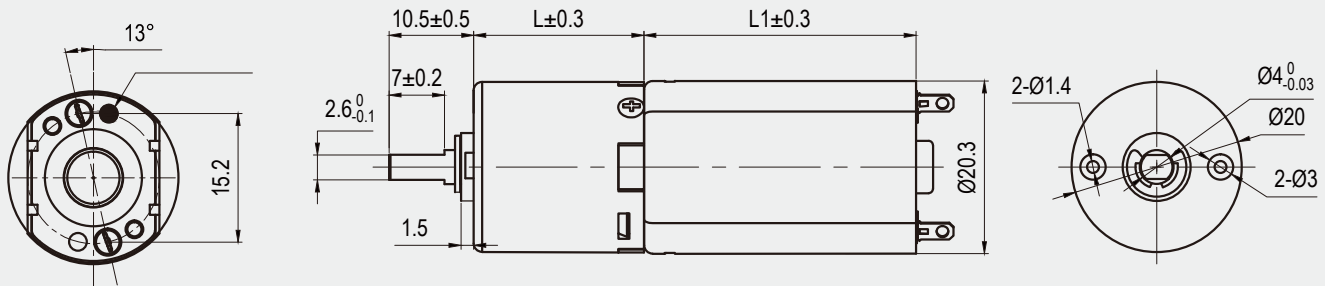

Weight: 47g

Unit (mm)

Voltage, rated torque, speed, current, power and shaft size can be customized as requirement.

Technical Data

MODEL	VOLTAGE	NO- LOAD		AT MAXIMUM EFFICIENCY				STALL TORQUE			GEAR RATIO	LENGTH OF GEAR BOX(L)	MATCH THE MOTOR	LENGTH OF MOTOR(L1)	
		SPEED	CURRENT	SPEED	CURRENT	TORQUE	OUTPUT	TORQUE	CURRENT						
	V	r/min	A	r/min	A	mN.m	Kg.cm	W	mN.m	Kg.cm	A	mm		mm	
JL-20PA130-36	3	180	0.21	139	0.40	0.02	0.20	0.29	0.08	0.80	1.15	36	3.5	JFF/K-130	25.1
JL-20PA180-36	12	320	0.18	256	0.46	0.02	0.30	0.79	0.15	1.50	1.7	36	3.5	JFF/K-180	1.7

Packing Details

QTY: 225 pcs/ctn Carton Size: 41*31*27.8 cm Gross Weight: 11.5 kg/ctn Net Weight: 10.5 kg/ctn



Typical Applications

- Household Appliances: Hair Curler
- Financial Medical Equipment: 3Doodler ,Projector
- Industrial Equipment: Air Switch
- Intelligent Robot: Mechanical Arm, UAV(Unmanned Aerial Vehicle), Service Robot

Outline Dimension

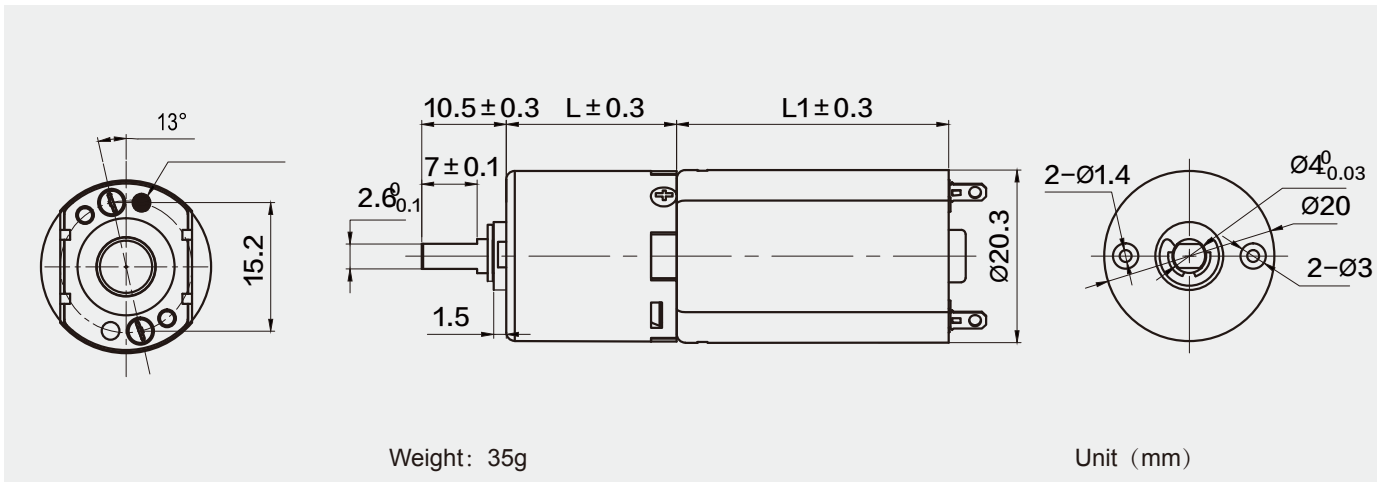

Voltage, rated torque, speed, current, power and shaft size can be customized as requirement.

Technical Data

MODEL	VOLTAGE V	NO-LOAD		AT MAXIMUM EFFICIENCY				STALL TORQUE			GEAR RATIO	LENGTH OF GEAR BOX(L) mm	MATCH THE MOTOR	LENGTH OF MOTOR(L1) mm
		SPEED r/min	CURRENT A	SPEED r/min	CURRENT A	TORQUE		TORQUE		CURRENT A				
						mN.m	Kg.cm	mN.m	Kg.cm					
JL-20PF180-24	12	270	0.08	237	0.13	17.2	0.17	60.2	0.60	0.85	24	19.5	JFF/K-180	32
JL-20PF180-64	12	102	0.09	90	0.13	30.2	0.31	105.7	1.09	0.85	64	23.5	JFF/K-180	32
JL-20PF180-256	12	24	0.09	22	0.13	90.6	0.91	317.1	3.19	0.85	256	28	JFF/K-180	32
JL-20PF180-864	12	7	0.09	6	0.13	306.0	3.11	1071	10.89	0.85	864	28	JFF/K-180	32

Packing Details

QTY: 400 pcs/ctn Carton Size: 36.5*26.5*25 cm Gross Weight: 15 kg/ctn Net Weight: 14 kg/ctn



Typical Applications

- Household Appliances: Hair Curler
- Financial Medical Equipment: 3Doodler ,Projector
- Industrial Equipment: Air Switch
- Intelligent Robot: Mechanical Arm, UAV(Unmanned Aerial Vehicle), Service Robot

Outline Dimension

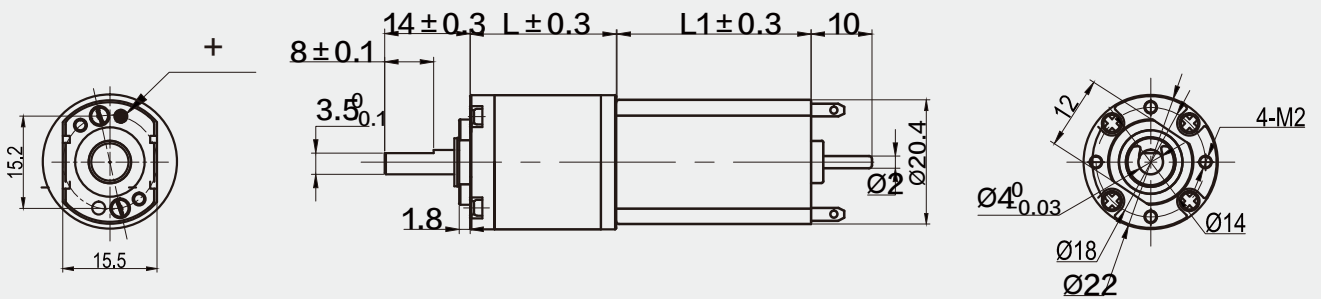

Weight: 35g

Unit (mm)

Voltage, rated torque, speed, current, power and shaft size can be customized as requirement.

Technical Data

MODEL	VOLTAGE	NO-LOAD		AT MAXIMUM EFFICIENCY				STALL TORQUE			GEAR RATIO	LENGTH OF GEAR BOX(L)	MATCH THE MOTOR	LENGTH OF MOTOR(L1)
		SPEED	CURRENT	SPEED	CURRENT	TORQUE		TORQUE	CURRENT					
		r/min	A	r/min	A	mN.m	Kg.cm	mN.m	Kg.cm	A				
JL-22P180-22.6	12	270	0.08	237	0.13	17.2	0.17	60.2	0.60	0.85	22.6	16.9	JFF/K-180	32
JL-22P180-64	12	102	0.09	90	0.13	30.2	0.31	105.7	1.09	0.85	64	20.5	JFF/K-180	32
JL-22P180-256	12	24	0.09	22	0.13	90.6	0.91	317.1	3.19	0.85	256	24.1	JFF/K-180	32
JL-22P180-864	12	7	0.09	6	0.13	306.0	3.11	1071	10.89	0.85	864	24.1	JFF/K-180	32

Packing Details

QTY: 400 pcs/ctn Carton Size: 36.5*26.5*25 cm Gross Weight: 15 kg/ctn Net Weight: 14 kg/ctn



Typical Applications

- Household Appliances: Electric curtain, Intergrated cooker, Coffee maker, Intelligent closetool, Sweeping robot, Dish-washing Machine, Cooker hood, Electric lock.
- Hair Care: Hair Curler, Massager, Electric Hair Clipper
- Office Equipment: Shredder, Printer, Projector, Counting Machine
- Medical Equipment: Massage chair, Electric trolley, Medical pump, Electric bed, Electric wheelchair
- Industrial Equipment: Water, electrical and gas valve, Air switch, Pump, Automatic door, Automatic lubrication equipment.
- Business Equipment: Vending machines, Parking locks, ATM machines, Stage lights.
- Intelligent Robot: Mechanical Arm, UAV (Unmanned Aerial Vehicle), Service Robot

Outline Dimension

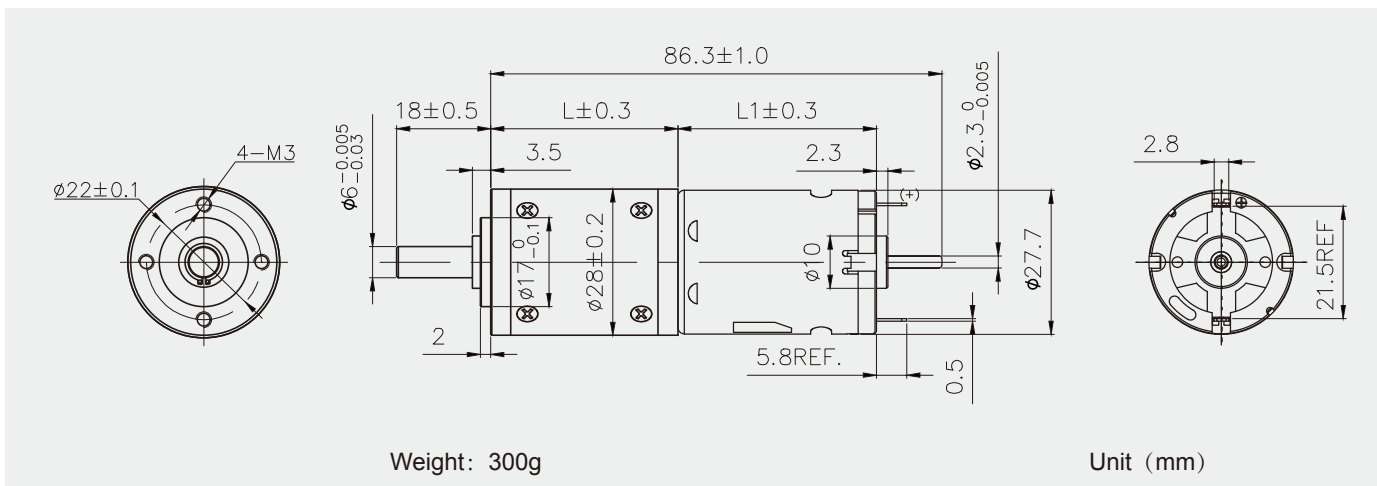

Voltage, rated torque, speed, current, power and shaft size can be customized as requirement.

Technical Data

MODEL	VOLTAGE	NO-LOAD		AT MAXIMUM EFFICIENCY				STALL TORQUE			GEAR RATIO	LENGTH OF GEAR BOX(L)	MATCH THE MOTOR	LENGTH OF MOTOR(L1)	
		SPEED	CURRENT	SPEED	CURRENT	TORQUE	OUTPUT	TORQUE	CURRENT	A					
	V	r/min	A	r/min	A	mN.m	Kg.cm	W	mN.m	Kg.cm	A	mm	mm	mm	
JL-28P395-27	24	310	0.15	248	0.40	123.1	1.23	5.5	430.9	4.31	1.6	27	30.9	JRS-395	47
JL-28P395-71	24	115	0.15	92	0.35	216.3	2.21	5.5	757.1	7.74	1.6	71	37.3	JRS-395	47
JL-28P395-100	24	75	0.15	60	0.35	324.5	3.25	5.5	1135.8	11.38	1.6	100	37.3	JRS-395	47
JL-28P395-263	24	28	0.15	22.4	0.35	648.9	6.52	5.5	2271.2	22.82	1.6	263	43.7	JRS-395	47
JL-28P395-720	24	11	0.15	8.8	0.35	2100	21.22	5.5	7,350.0	74.27	1.6	720	43.7	JRS-395	47

Packing Details

QTY: 80 pcs/ctn Carton Size: 40.5*28*25 cm Gross Weight: 23 kg/ctn Net Weight: 22 kg/ctn



Typical Applications

- Household Appliances: Electric curtain, Intergrated cooker, Coffee maker, Intelligent closetool, Sweeping robot, Dish-washing Machine, Cooker hood, Electric lock.
- Hair Care: Hair Curler, Massager, Electric Hair Clipper
- Office Equipment: Shredder, Printer, Projector, Counting Machine
- Medical Equipment: Massage chair, Electric trolley, Medical pump, Electric bed, Electric wheelchair
- Industrial Equipment: Water, electrical and gas valve, Air switch, Pump, Automatic door, Automatic lubrication equipment.
- Business Equipment: Vending machines, Parking locks, ATM machines, Stage lights.
- Intelligent Robot: Mechanical Arm, UAV (Unmanned Aerial Vehicle), Service Robot

Outline Dimension

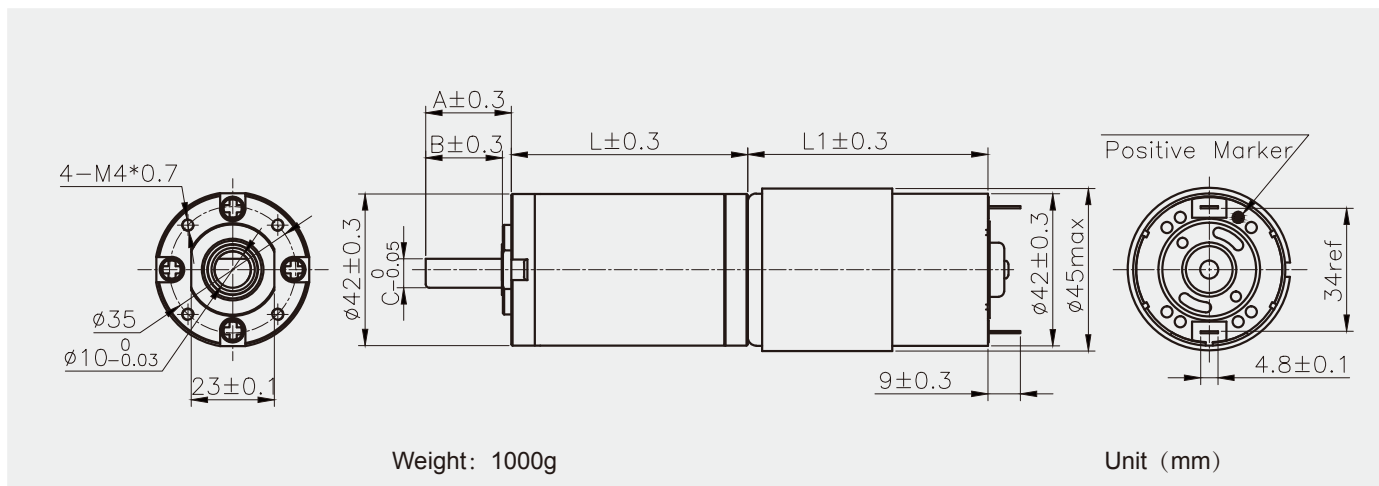

Voltage, rated torque, speed, current, power and shaft size can be customized as requirement.

Technical Data

MODEL	VOLTAGE	NO-LOAD		AT MAXIMUM EFFICIENCY			STALL TORQUE			GEAR RATIO	LENGTH OF GEAR BOX(L)	MATCH THE MOTOR	LENGTH OF MOTOR(L1)
		SPEED	CURRENT	SPEED	CURRENT	TORQUE	TORQUE	CURRENT					
	V	r/min	A	r/min	A	mN.m	Kg.cm	mN.m	Kg.cm	A	mm		mm
JL-42P775-104	24	58	0.550	48	2.63	3524.8	35.94	10574.4	107.83	12.50	104	JRS-775	66.5
JL-42P775-120	24	50	0.550	42	2.63	4036.5	41.16	12109.5	123.48	12.50	120	JRS-775	66.5
JL-42P775-139	24	43	0.550	36	2.63	4583.2	46.73	13749.6	140.20	12.50	139	JRS-775	66.5
JL-42P775-158	24	38	0.550	32	2.63	5045.3	51.45	15135.9	154.34	12.50	158	JRS-775	66.5

Packing Details

QTY: 15pcs/ctn Carton Size: 36.5*26.5*24cm Gross Weight: 16 kg/ctn Net Weight: 15 kg/ctn