

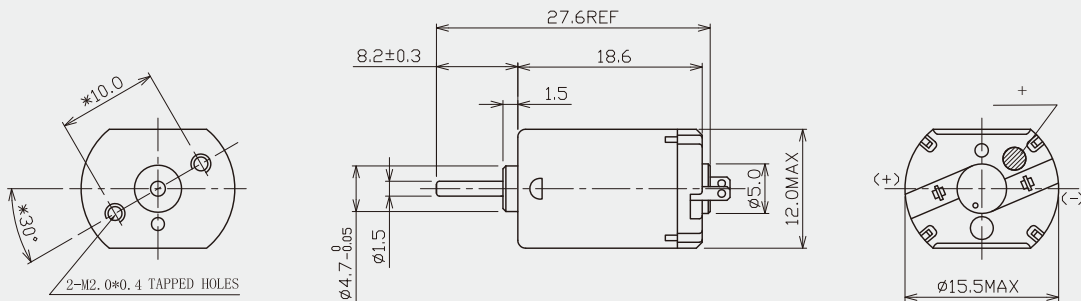

## Typical Applications

- Household Appliances: CD/DVD player, Camera, Blood pressure meter, Camera, Rice cooker.
- Hair Care: Electric shaver.
- Office Equipment: Printer, Projector, Counting Machine.

## Outline Dimension



Weight: 11g

WEIGHT: 11.0g (APPROX)  
UNIT: Millimeters

Unit (mm)

Voltage, rated torque, speed, current, power and shaft size can be customized as requirement.

## Technical Data

MODEL	VOLTAGE(V)		NO-LOAD		AT MAXIMUM EFFICIENCY				STALL			
	OPERATING RANGE	NOMINAL	SPEED	CURRENT	SPEED	CURRENT	TORQUE		OUTPUT	TORQUE		CURRENT
			r/min	A	r/min	A	mN.m	g.cm	W	mN.m	g.cm	A
JFF-030P-10155	1.5~12	6V CONSTANT	16000	0.05	14000	0.15	0.5	5.0	0.28	4.4	44.0	0.98
JFF-030P-188009	1.5~12	5V CONSTANT	10500	0.03	8300	0.13	0.6	6.0	0.14	2.8	28.0	0.55
JFK-030P-12140	3~12	6V CONSTANT	18000	0.09	15000	0.31	1.0	10.0	0.51	6.1	61.0	1.55
JFK-030P-140011	3~12	5V CONSTANT	15000	0.07	12000	0.28	0.9	9.0	0.33	4.5	45.0	1.14
JFK-030P-350007	3~12	12V CONSTANT	14500	0.04	11300	0.10	0.8	7.5	0.45	3.4	34.0	0.40
JFF-030PA-10180	1.5~6	5V CONSTANT	11700	0.05	9230	0.19	0.5	5.1	0.48	2.4	24.0	0.70
JFF-030PK-09210	1.5~6	5V CONSTANT	10500	0.05	8140	0.16	0.4	4.5	0.37	2.0	20.0	0.55
JFF-030PK-08250	1.5~6	2.5V CONSTANT	4100	0.03	2940	0.07	0.2	2.1	0.06	0.7	7.6	0.18

## Packing Details

QTY: 400 pcs/ctn Carton Size: 36.5\*26.5\*24 cm Gross Weight: 8.5 kg/ctn Net Weight: 7.5kg/ctn



### Typical Applications

- Household Appliances: CD/DVD player, Camera, Blood pressure meter, Camera, Rice cooker.
- Hair Care: Electric shaver.
- Office Equipment: Printer, Projector, Counting Machine.

### Outline Dimension

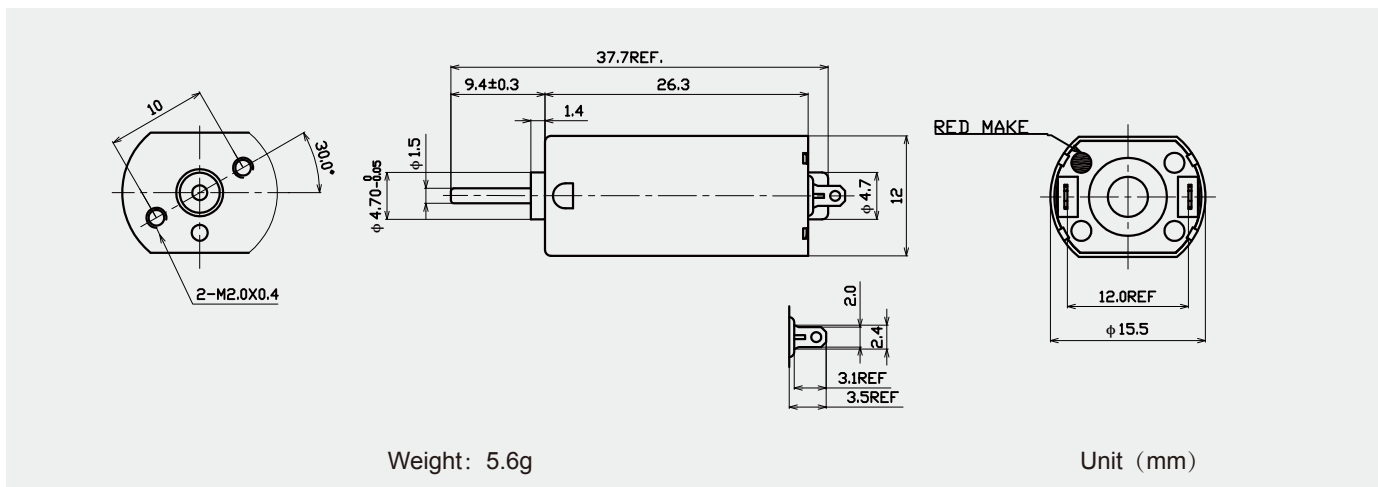

Voltage, rated torque, speed, current, power and shaft size can be customized as requirement.

### Technical Data

MODEL	VOLTAGE(V)		NO- LOAD		AT MAXIMUM EFFICIENCY					STALL		
	OPERATING RANGE	NOMINAL	SPEED r/min	CURRENT A	SPEED r/min	CURRENT A	TORQUE mN.m	TORQUE g.cm	OUTPUT W	TORQUE mN.m	TORQUE g.cm	CURRENT A
JFF-050S-10170	3~6	3.3V CONSTANT	4500	0.03	3800	0.03	1.0	10.0	0.08	6.3	63.0	0.31
JFF-050S-180010	3~6	3.6V CONSTANT	5000	0.03	4000	0.09	0.5	5.0	0.10	2.4	24.0	0.32
JFK-050S-08280	3~6	5.0V CONSTANT	4000	0.03	3000	0.07	0.5	5.0	0.16	2.0	20.0	0.19
JFK-050S-068016	1.5~5	3.0V CONSTANT	11000	0.16	8600	0.44	0.8	7.5	0.46	4.1	41.0	1.00
JFK-050S-083015	3~12	6.0V CONSTANT	18000	0.15	15000	0.46	0.8	7.5	0.86	4.8	48.0	2.00
JFK-050S-100013	3~12	6.0V CONSTANT	15000	0.11	12600	0.30	0.8	7.5	0.64	5.0	50.0	1.50
JFK-050SH-13125	3~12	6.0V CONSTANT	11500	0.09	9100	0.34	1.1	11.4	1.07	5.4	55.0	1.30

### Packing Details

QTY: 1000 pcs/ctn    Carton Size: 36.0\*26.5\*19 cm    Gross Weight: 6.6 kg/ctn    Net Weight: 5.6 kg/ctn

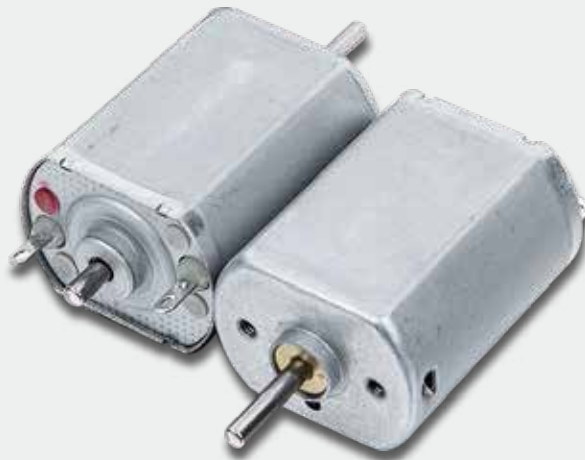

## Typical Applications

- Household Appliances: CD/DVD player, Camera, Blood pressure meter, Camera, Rice cooker.
- Hair Care: Electric shaver.
- Office Equipment: Printer, Projector, Counting Machine.

## Outline Dimension

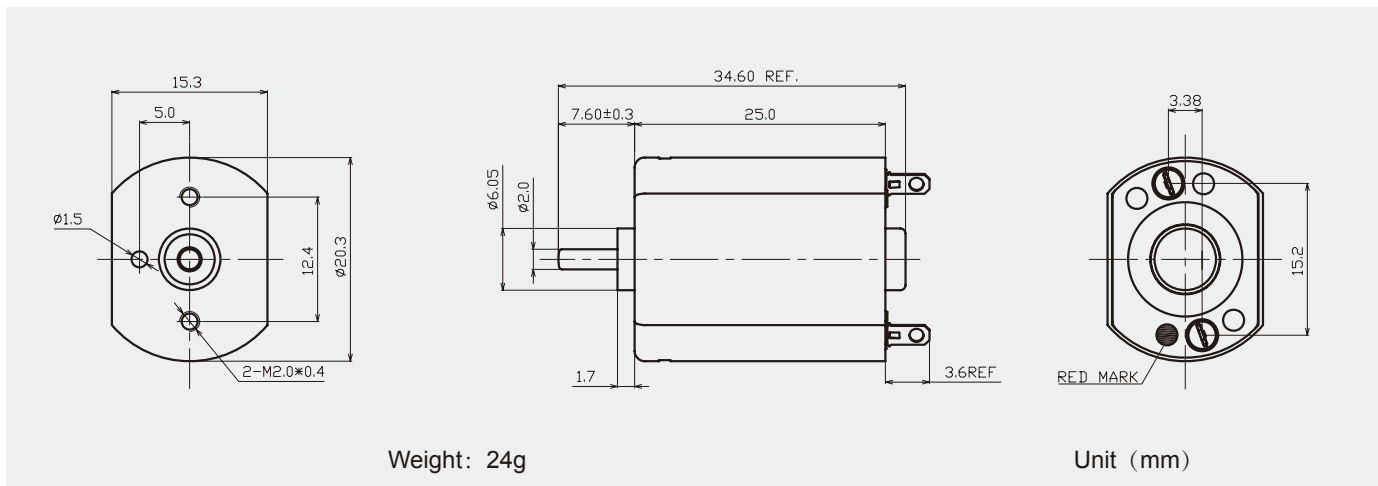

Voltage, rated torque, speed, current, power and shaft size can be customized as requirement.

## Technical Data

MODEL	VOLTAGE(V)		NO-LOAD		AT MAXIMUM EFFICIENCY				STALL			
	OPERATING RANGE	NOMINAL	SPEED	CURRENT	SPEED	CURRENT	TORQUE		OUTPUT	TORQUE		CURRENT
			r/min	A	r/min	A	mN.m	g.cm	W	mN.m	g.cm	A
JFF-130SH-10385	3~12	6.0V CONSTANT	4800	0.02	3500	0.09	1.0	10.0	0.13	3.9	39.0	0.30
JFF-130SH-14175	3~12	3.7V CONSTANT	6000	0.06	4800	0.20	1.0	10.0	0.20	5.2	52.0	0.80
JFK-130SH-290011	3~12	12V CONSTANT	12000	0.08	8700	0.28	2.0	20.0	0.90	7.4	74.1	0.88
JFK-130SH-09450	3~12	12V CONSTANT	7400	0.03	5300	0.14	2.0	20.0	0.34	6.9	69.0	0.41
JFK-130SH-12265	3~12	12V CONSTANT	13000	0.09	10000	0.33	2.5	25.0	1.01	11.2	112.0	1.20
JFK-130SH-15160	3~12	12V CONSTANT	22000	0.19	16500	0.74	3.0	30.0	2.13	12.9	129.0	2.90
JFK-130SH-140016	3~12	12V CONSTANT	23500	0.18	17500	0.89	3.5	35.0	2.05	15.5	155.1	3.10
JFF-130RH-15210	1~6	3.0V CONSTANT	5400	0.05	4280	0.17	0.6	5.8	0.26	2.7	28.0	0.65
JFF-130RH-2860	1~6	1.2V CONSTANT	7400	0.21	5870	0.81	0.8	7.8	0.47	3.7	38.0	3.10
JFF-130SH-11340	3~12	6.0V CONSTANT	4800	0.03	3820	0.12	0.9	8.9	0.35	4.3	44.0	0.46
		9.0V CONSTANT	7400	0.04	6030	0.15	1.2	12.0	0.74	6.4	65.0	0.68

## Packing Details

QTY: 400 pcs/ctn Carton Size: 36.5\*26.5\*24 cm Gross Weight: 8.5 kg/ctn Net Weight: 7.5 kg/ctn



### Typical Applications

- Household Appliances: CD/DVD player, Camera, Blood pressure meter, Camera, Rice cooker.
- Hair Care: Electric shaver.
- Office Equipment: Printer, Projector, Counting Machine.

### Outline Dimension

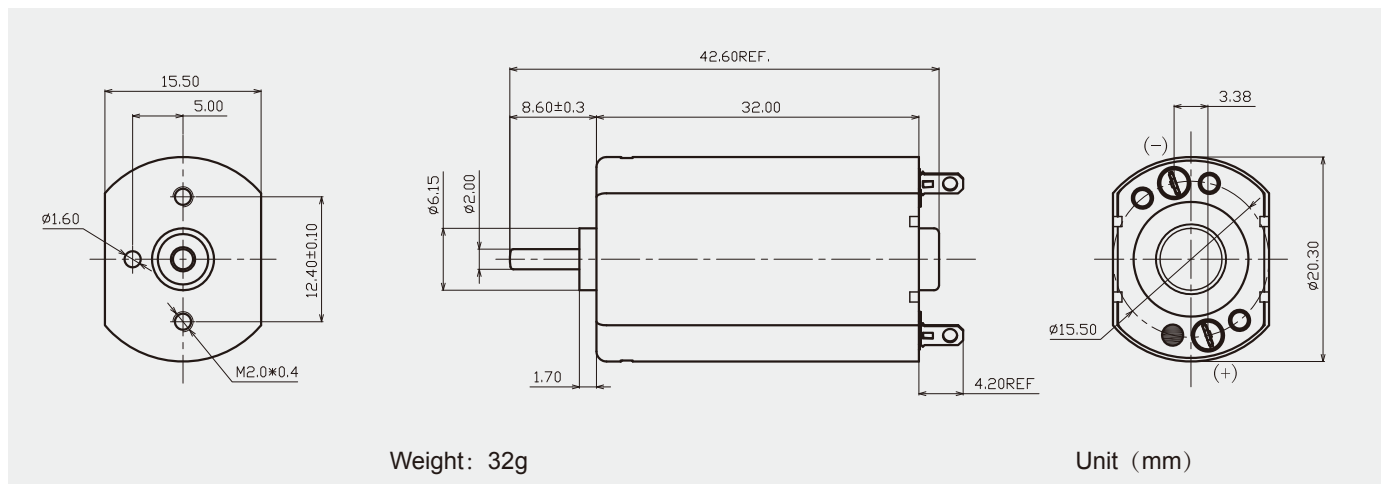

Voltage, rated torque, speed, current, power and shaft size can be customized as requirement.

### Technical Data

MODEL	VOLTAGE(V)		NO- LOAD		AT MAXIMUM EFFICIENCY				STALL			
	OPERATING RANGE	NOMINAL	SPEED	CURRENT	SPEED	CURRENT	TORQUE		OUTPUT	TORQUE		CURRENT
			r/min	A	r/min	A	mN.m	g.cm	W	mN.m	g.cm	A
JFF-180SH-395009	3~12	6.0V CONSTANT	2400	0.02	1750	0.06	1.0	10.0	0.11	3.8	38.0	0.18
JFF-180SH-510008	6~24	24V CONSTANT	8000	0.02	6200	0.12	3.0	30.0	0.48	13.5	135.0	0.48
JFK-180SH-102020	3~12	5.0V CONSTANT	8000	0.12	6200	0.56	3.0	30.0	0.57	14.2	142.0	0.80
JFK-180SH-175015	6~24	12V CONSTANT	12000	0.09	8600	0.57	5.0	50.0	0.97	17.7	177.0	1.20
JFK-180SH-255012	6~24	12V CONSTANT	8000	0.06	6000	0.26	3.0	30.0	0.67	12.1	121.0	0.91
JFK-180SH-09450	12~24	12V CONSTANT	4400	0.02	3500	0.08	1.3	13.6	0.49	6.5	67.0	0.32
		24V CONSTANT	9200	0.03	7660	0.12	2.1	21.6	1.70	12.7	130.0	0.62
JFK-180SH-17140	6~24	6.0V CONSTANT	7800	0.09	6390	0.39	2.0	20.8	1.36	11.3	115.0	0.50
JFF-180PH-2852	1~6	2.4V CONSTANT	8100	0.15	6850	0.82	1.8	18.6	1.30	11.8	120.0	0.45
JFF-180PH-4022	1~5	1.2V CONSTANT	9400	0.40	7830	1.99	1.8	17.9	1.44	10.5	107.0	1.00
JFF-180SH-10320	12~24	12V CONSTANT	6500	0.03	5280	0.12	1.5	15.4	0.84	8.0	82.0	0.52
JFF-180SH-2657	1~5	2.4V CONSTANT	7700	0.13	6500	0.70	1.6	15.9	1.06	10.0	102.0	0.38
JFF-180SH-14210	3~6	4.5V CONSTANT	3700	0.03	3090	0.13	1.0	10.4	0.33	6.2	63.0	0.63
JFF-180SH-4026	1~5	1.2V CONSTANT	8300	0.30	6990	1.60	1.6	16.7	1.20	10.4	106.0	0.85

### Packing Details

QTY: 400 pcs/ctn Carton Size: 36.5\*26.5\*24 cm Gross Weight: 13 kg/ctn Net Weight: 12 kg/ctn



### Typical Applications

- Household Appliances: CD/DVD player, Camera, Blood pressure meter, Camera, Rice cooker.
- Hair Care: Electric shaver.
- Office Equipment: Printer, Projector, Counting Machine.

### Outline Dimension

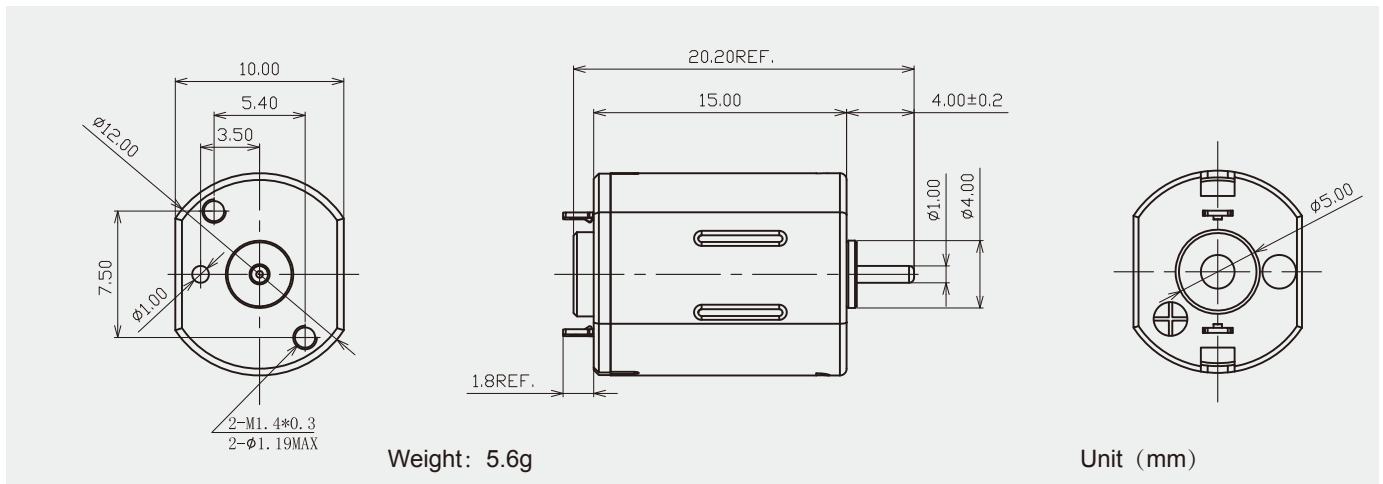

Voltage, rated torque, speed, current, power and shaft size can be customized as requirement.

### Technical Data

MODEL	VOLTAGE(V)		NO-LOAD		AT MAXIMUM EFFICIENCY					STALL		
	OPERATING RANGE	NOMINAL	SPEED	CURRENT	SPEED	CURRENT	TORQUE		OUTPUT	TORQUE		CURRENT
			r/min	A	r/min	A	mN.m	g.cm	W	mN.m	g.cm	A
JFF-N20-09175	3~12	6v CONSTANT	21000	0.04	16000	0.20	0.5	5.0	0.23	2.2	22.0	0.78
JFF-N20-175010	3~12	4.2v CONSTANT	14500	0.03	11500	0.17	0.5	5.0	0.14	2.4	24.0	0.69
JFF-N20-185009	3~12	5v CONSTANT	16900	0.04	13800	0.14	0.5	5.0	0.18	1.8	18.0	0.61
JFF-N20-196010	3~12	5v CONSTANT	15200	0.03	11400	0.22	0.8	7.5	0.14	2.2	22.0	0.77
JFF-N20-230008	3~12	3.7v CONSTANT	9200	0.02	6500	0.10	0.5	5.00	0.08	1.8	18.0	0.31
JFF-N20-10190	2~5	3V CONSTANT	12100	0.05	9390	0.16	0.2	2.1	0.20	0.9	9.4	0.54
JFF-N20-08260	1.5~6	3V CONSTANT	8200	0.04	5920	0.10	0.2	1.8	0.11	0.6	6.3	0.27

### Packing Details

QTY: 1000 pcs/ctn Carton Size: 36.0\*26.5\*19 cm Gross Weight: 6.6 kg/ctn Net Weight: 5.6 kg/ctn