

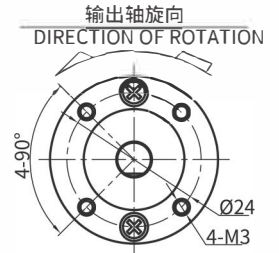

外形图 (单位 mm) Dimensions(Unit mm)

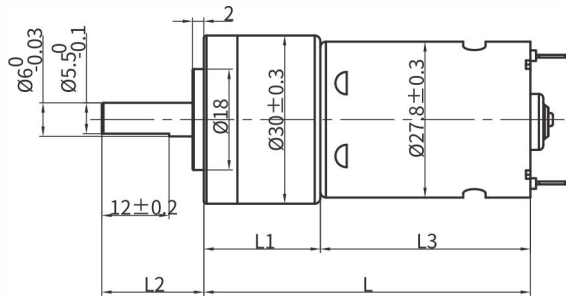
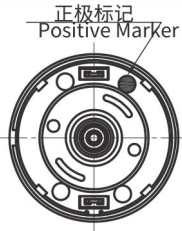

电压, 扭矩, 转速, 电流, 功率, 轴的尺寸可以按照客户需求定制。
Voltage, Rated torque, Speed, Current, Power and Shaft size can be customized as requirement.

齿轮箱规格 Gearbox specifications

外径 Outer diameter	$\phi 30$	轴承 Bearing				含油轴承 Porous Bearing	选配电机 Optional motor	长度 Length
材质 Material	金属 Metal	轴向往动 Axial endplay				$\leq 0.3\text{mm}$	RK-365	32.7
旋转方向 Direction of rotation	cc&ccw	工作温度 Operating temperature range				$-20 \sim +65^\circ\text{C}$	RK-385	37.8
齿轮级数 Gearbox stages		2	3	4	5	6	7	
传动比 Transmission ratio		5	7.5	1417	27 32	5167	98 141518	
最大容许扭力 (gf.cm max) Max rated torque of gear box		500	1500	2000	2000	2000	2000	
瞬间容许力矩 (gf.cm max) Instant torque of gear box		1000	3000	5000	4000	4000	4000	
齿轮箱效率 % Gearbox efficiency		81	72	65	59	47	43	
长度 Length		19	20.8	20.8	23.3	25.8	28.3	

技术数据 Technical Data

型号 MODEL	电压 (V) VOLTAGE(V)		空载 NO-LOAD		负载参数 LOAD PARAMETER					堵转 STALL		齿轮箱长度 (L) GEARBOX LENGTH	匹配电机 MATCHING MOTOR	电机长度 (L1) MOTOR LENGTH	
	使用范围 OPERATING RANGE	额定值 NOMINAL	转速 SPEED r/min	电流 CURRENT A	转速 SPEED r/min	电流 CURRENT A	转矩 TORQUE mN.m	功率 OUTPUT g.cm	转矩 TORQUE mN.m	电流 CURRENT g.cm					
JL-30A385-5	16~24	24	1370	0.158	1132	0.44	29.4	300	3.48	137.3	1400	1.70	23	385	37.5
JL-30A385-14.2	16~24	24	462	0.130	372	0.40	58.8	600	2.29	343.1	3500	1.35	23	385	37.5
JL-30A385-27	16~24	24	240	0.120	182	0.60	196.1	2000	3.73	980.4	10000	1.40	23	385	37.5
JL-30A385-32	16~24	24	205	0.123	155	0.65	196.1	2000	3.18	1176.5	12000	1.40	23	385	37.5
JL-30A385-51	16~24	24	130	0.086	94	0.70	294.1	3000	2.89	1862.7	19000	1.40	23	385	37.5
JL-30A385-68	16~24	24	59	0.134	54	0.31	196.1	2000	1.11	1470.6	15000	2.00	23	385	37.5
JL-30A385-98	16~24	24	37	0.160	35.5	0.30	294.1	3000	1.09	0.0	-	1.74	23	385	37.5
JL-30A385-141	16~24	24	18	0.100	14.4	0.43	196.1	2000	0.30	0.0	-	2.90	23	385	37.5
JL-30A385-518	16~24	24	15	0.150	12	0.45	294.1	3000	0.37	0.0	-	2.90	23	385	37.5

装箱信息 Packing Details

数量: 80pcs/ctn 纸箱尺寸: 40.5*28*25 cm 毛重: 12.5 kg/ctn 净重: 11.5 kg/ctn 单重: 144 g
QTY: 80pcs/ctn Carton Size: 40.5*28*25 cm Gross Weight: 12.5 kg/ctn Net Weight: 11.5 kg/ctn Unit Weight :144 g



Typical Applications

- Household Appliances: Electric curtain, Intergrated cooker, Coffee maker, Intelligent closetool, Sweeping robot, Dish-washing Machine, Cooker hood, Electric lock.
- Hair Care: Hair Curler, Massager, Electric Hair Clipper
- Office Equipment: Shredder, Printer, Projector, Counting Machine
- Medical Equipment: Massage chair, Electric trolley, Medical pump, Electric bed, Electric wheelchair
- Industrial Equipment: Water, electrical and gas valve, Air switch, Pump, Automatic door, Automatic lubrication equipment.
- Business Equipment: Vending machines, Parking locks, ATM machines, Stage lights.
- Intelligent Robot: Mechanical Arm, UAV (Unmanned Aerial Vehicle), Service Robot

Outline Dimension

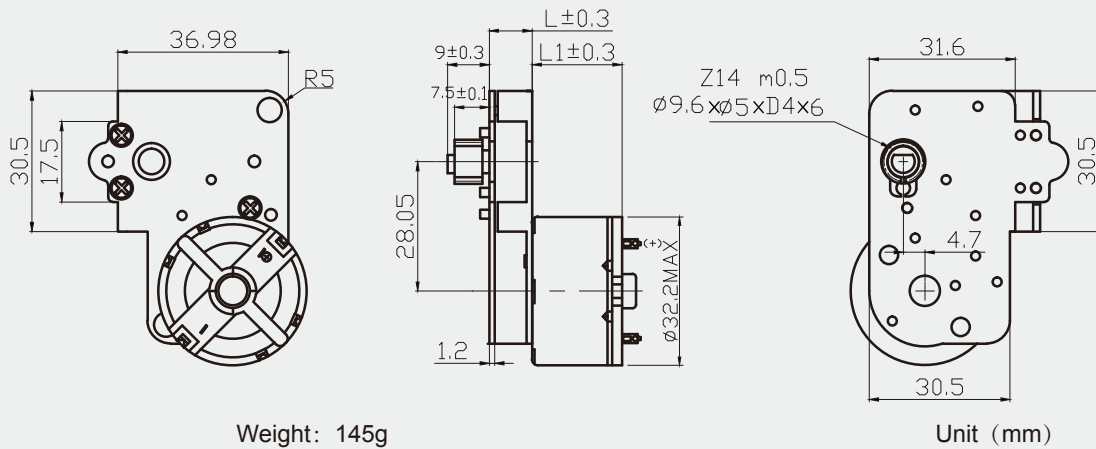

Voltage, rated torque, speed, current, power and shaft size can be customized as requirement.

Technical Data

MODEL	VOLTAGE	NO-LOAD		AT MAXIMUM EFFICIENCY				STALL TORQUE			GEAR RATIO	LENGTH OF GEAR BOX (L)	MATCH THE MOTOR	LENGTH OF MOTOR (L1)
		SPEED	CURRENT	SPEED	CURRENT	TORQUE		TORQUE	CURRENT					
		V	r/min	A	r/min	A	mN.m	Kg.cm	mN.m	Kg.cm				
JL-30F500-147	3	8	0.02	6.5	0.05	58.8	0.6	294.1	3	0.16	147	9.3	500	54.8

Packing Details

QTY: 80pcs/ctn Carton Size: 40.5*28*25 cm Gross Weight: .12.5 kg/ctn Net Weight: 11.5 kg/ctn



Typical Applications

- Household Appliances: Electric curtain, Intergrated cooker, Coffee maker, Intelligent closetool, Sweeping robot, Dish-washing Machine, Cooker hood, Electric lock.
- Hair Care: Hair Curler, Massager, Electric Hair Clipper
- Office Equipment: Shredder, Printer, Projector, Counting Machine
- Medical Equipment: Massage chair, Electric trolley, Medical pump, Electric bed, Electric wheelchair
- Industrial Equipment: Water, electrical and gas valve, Air switch, Pump, Automatic door, Automatic lubrication equipment.
- Business Equipment: Vending machines, Parking locks, ATM machines, Stage lights.
- Intelligent Robot: Mechanical Arm, UAV (Unmanned Aerial Vehicle), Service Robot

Outline Dimension

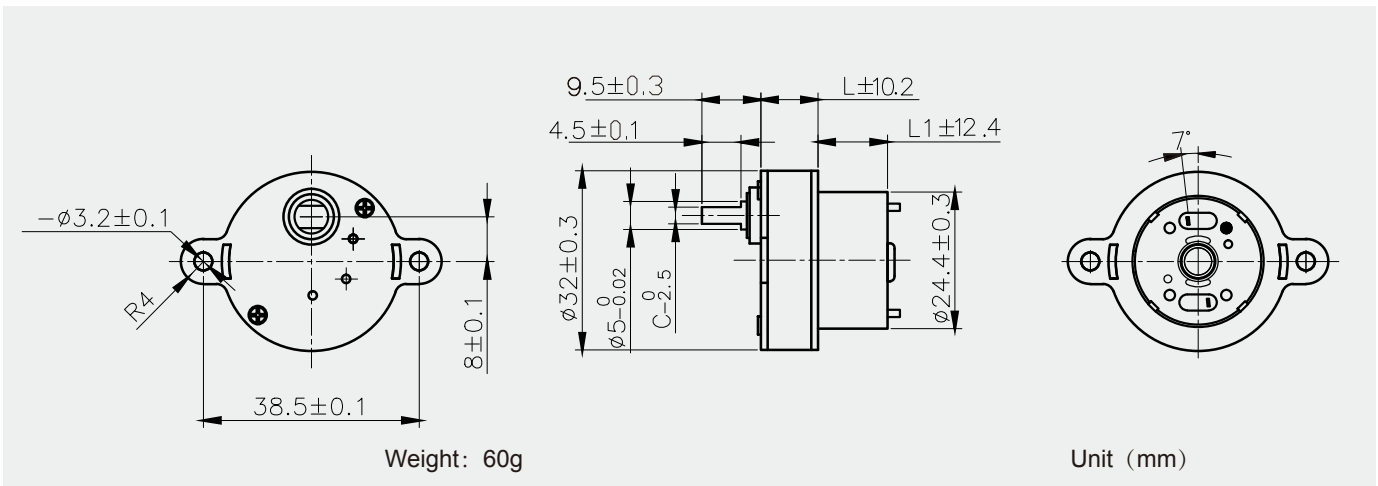

Voltage, rated torque, speed, current, power and shaft size can be customized as requirement.

Technical Data

MODEL	VOLTAGE	NO- LOAD		AT MAXIMUM EFFICIENCY			STALL TORQUE			GEAR RATIO	LENGTH OF GEAR BOX(L)	MATCH THE MOTOR	LENGTH OF MOTOR(L1)	
		SPEED	CURRENT	SPEED	CURRENT	TORQUE	TORQUE	CURRENT						
	V	r/min	A	r/min	A	mN.m	Kg.cm	mN.m	Kg.cm	A	mm	mm		
JL-32B300-10	12	854	0.050	596	0.100	5.3	0.05	17.4	0.18	0.26	10	10.2	JRF/K-300	12.4
JL-32B300-44	12	194	0.050	136	0.100	23.3	0.24	76.5	0.78	0.26	44	10.2	JRF/K-300	12.4
JL-32B300-56	12	152	0.056	107	0.111	29.7	0.30	97.4	0.99	0.26	56	10.2	JRF/K-300	12.4
JL-32B300-90	12	95	0.056	66	0.111	47.7	0.49	156.6	1.60	0.26	90	10.2	JRF/K-300	12.4
JL-32B300-130	12	66	0.056	46	0.111	68.9	0.70	226.1	2.31	0.26	130	10.2	JRF/K-300	12.4
JL-32B300-142	12	60	0.056	42	0.111	75.2	0.77	247.0	2.52	0.26	142	10.2	JRF/K-300	12.4
JL-32B300-227	12	38	0.063	26	0.125	120.3	1.23	394.9	4.03	0.26	227	10.2	JRF/K-300	12.4
JL-32B300-360	12	24	0.063	17	0.125	130.5	1.33	450.5	4.59	0.26	360	10.2	JRF/K-300	12.4

Packing Details

QTY: 250pcs/ctn Carton Size: 36.5*26.5*24 cm Gross Weight: .12.5 kg/ctn Net Weight: 12 kg/ctn



Typical Applications

- Household Appliances: Electric curtain, Intergrated cooker, Coffee maker, Intelligent closetool, Sweeping robot, Dish-washing Machine, Cooker hood, Electric lock.
- Hair Care: Hair Curler, Massager, Electric Hair Clipper
- Office Equipment: Shredder, Printer, Projector, Counting Machine
- Medical Equipment: Massage chair, Electric trolley, Medical pump, Electric bed, Electric wheelchair
- Industrial Equipment: Water, electrical and gas valve, Air switch, Pump, Automatic door, Automatic lubrication equipment.
- Business Equipment: Vending machines, Parking locks, ATM machines, Stage lights.
- Intelligent Robot: Mechanical Arm, UAV (Unmanned Aerial Vehicle), Service Robot

Outline Dimension

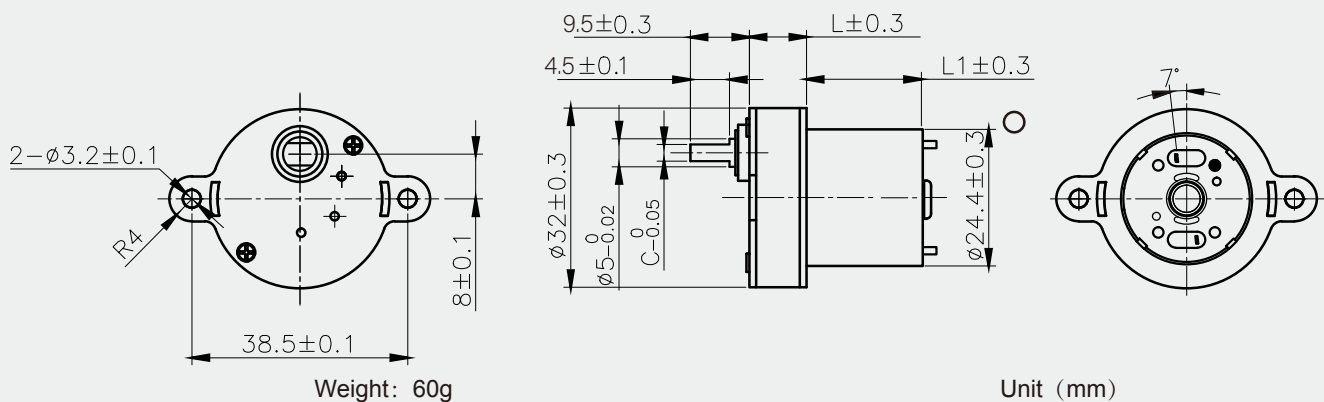

Voltage, rated torque, speed, current, power and shaft size can be customized as requirement.

Technical Data

MODEL	VOLTAGE	NO-LOAD		AT MAXIMUM EFFICIENCY			STALL TORQUE			GEAR RATIO	LENGTH OF GEAR BOX (L)	MATCH THE MOTOR	LENGTH OF MOTOR (L1)	
		SPEED	CURRENT	SPEED	CURRENT	TORQUE	TORQUE	CURRENT						
	V	r/min	A	r/min	A	mN.m	Kg.cm	mN.m	Kg.cm	A	mm	mm		
JL-32B310-10	3	114	0.01	85	0.02	1.4	0.01	4.6	0.05	0.12	10	10.2	JRF/K-310	18.1
JL-32B310-44	3	26	0.01	19	0.02	6.1	0.06	20.0	0.20	0.12	44	10.2	JRF/K-310	18.1
JL-32B310-56	3	20	0.01	15	0.02	7.7	0.08	25.5	0.26	0.12	56	10.2	JRF/K-310	18.1
JL-32B310-90	3	13	0.01	9	0.02	12.4	0.13	41.0	0.42	0.12	90	10.2	JRF/K-310	18.1
JL-32B310-130	3	9	0.01	7	0.02	17.9	0.18	59.2	0.60	0.12	130	10.2	JRF/K-310	18.1
JL-32B310-142	3	8	0.01	6	0.02	19.6	0.20	64.7	0.66	0.12	142	10.2	JRF/K-310	18.1
JL-32B310-227	3	5	0.01	4	0.02	31.3	0.32	103.4	1.05	0.12	227	10.2	JRF/K-310	18.1
JL-32B310-360	3	3	0.01	2	0.02	49.7	0.51	164.0	1.67	0.12	360	10.2	JRF/K-310	18.1

Packing Details

QTY: 250pcs/ctn Carton Size: 36.5*26.5*24 cm Gross Weight: .12.5 kg/ctn Net Weight: 12 kg/ctn



Typical Applications

- Household Appliances: Electric curtain, Integrated cooker, Coffee maker, Intelligent closetool, Sweeping robot, Dish-washing Machine, Cooker hood, Electric lock.
- Hair Care: Hair Curler, Massager, Electric Hair Clipper
- Office Equipment: Shredder, Printer, Projector, Counting Machine
- Medical Equipment: Massage chair, Electric trolley, Medical pump, Electric bed, Electric wheelchair
- Industrial Equipment: Water, electrical and gas valve, Air switch, Pump, Automatic door, Automatic lubrication equipment.
- Business Equipment: Vending machines, Parking locks, ATM machines, Stage lights.
- Intelligent Robot: Mechanical Arm, UAV (Unmanned Aerial Vehicle), Service Robot

Outline Dimension

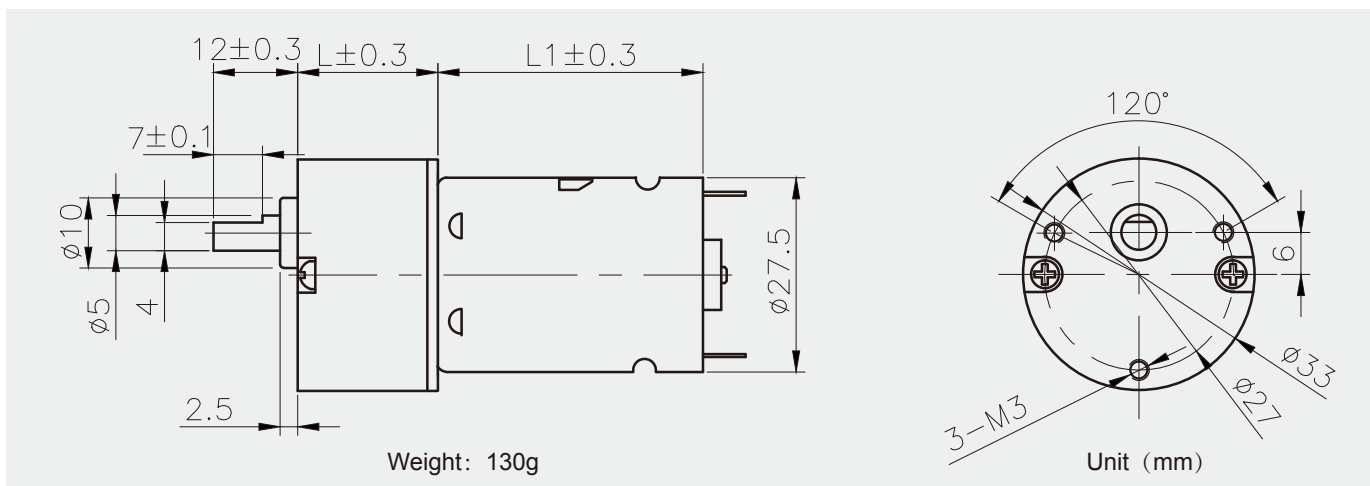

Voltage, rated torque, speed, current, power and shaft size can be customized as requirement.

Technical Data

MODEL	VOLTAGE	NO- LOAD		AT MAXIMUM EFFICIENCY				STALL TORQUE			GEAR RATIO	LENGTH OF GEAR BOX (L)	MATCH THE MOTOR	LENGTH OF MOTOR (L1)
		SPEED	CURRENT	SPEED	CURRENT	TORQUE		TORQUE	CURRENT					
		r/min	A	r/min	A	mN.m	Kg.cm	mN.m	Kg.cm	A				
JL-33B365-19	12	225	0.070	166	0.140	29.2	0.30	87.6	0.89	0.4	19	20	JRK-365	32.6
JL-33B365-46	12	93	0.070	69	0.140	70.7	0.72	212.1	2.16	0.4	46	20	JRK-365	32.6
JL-33B365-116	12	37	0.078	27	0.156	152.4	1.55	304.8	3.11	0.4	116	22	JRK-365	32.6
JL-33B365-292	12	15	0.078	11	0.156	252.5	2.57	883.8	9.01	0.4	292	22	JRK-365	32.6

Packing Details

QTY: 80pcs/ctn Carton Size: 40.5*28*25 cm Gross Weight: .11.5 kg/ctn Net Weight: 11 kg/ctn



Typical Applications

- Household Appliances: Electric curtain, Intergrated cooker, Coffee maker, Intelligent closetool, Sweeping robot, Dish-washing Machine, Cooker hood, Electric lock.
- Hair Care: Hair Curler, Massager, Electric Hair Clipper
- Office Equipment: Shredder, Printer, Projector, Counting Machine
- Medical Equipment: Massage chair, Electric trolley, Medical pump, Electric bed, Electric wheelchair
- Industrial Equipment: Water, electrical and gas valve, Air switch, Pump, Automatic door, Automatic lubrication equipment.
- Business Equipment: Vending machines, Parking locks, ATM machines, Stage lights.
- Intelligent Robot: Mechanical Arm, UAV (Unmanned Aerial Vehicle), Service Robot

Outline Dimension

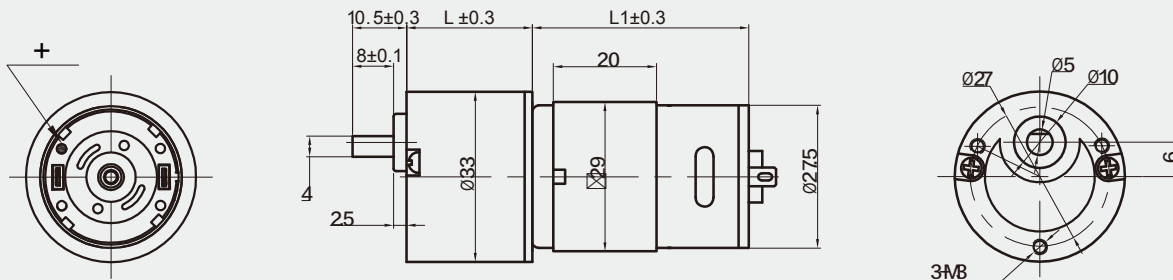

Weight: 130g

Unit (mm)

Voltage, rated torque, speed, current, power and shaft size can be customized as requirement.

Technical Data

MODEL	VOLTAGE	NO-LOAD		AT MAXIMUM EFFICIENCY			STALL TORQUE			GEAR RATIO	LENGTH OF GEAR BOX(L)	MATCH THE MOTOR	LENGTH OF MOTOR(L1)
		SPEED	CURRENT	SPEED	CURRENT	TORQUE	TORQUE	CURRENT					
	V	r/min	A	r/min	A	mN.m	Kg.cm	mN.m	Kg.cm	A	mm		mm
JL-33B385-19	20	794	0.210	659	1.05	85.2	0.87	213.0	2.17	5.4	19	JRK-385	37.8
JL-33B385-46	20	328	0.210	272	1.05	95.6	0.97	239.0	2.44	5.4	46	JRK-385	37.8
JL-33B385-116	20	130	0.233	108	1.17	125.2	1.28	502.4	5.12	5.4	116	JRK-385	37.8
JL-33B385-292	20	52	0.233	43	1.17	285.2	2.91	998.2	10.18	5.4	292	JRK-385	37.8

Packing Details

QTY: 80pcs/ctn Carton Size: 40.5*28*25 cm Gross Weight: .11.5 kg/ctn Net Weight: 11 kg/ctn



Typical Applications

- Household Appliances: Electric curtain, Intergrated cooker, Coffee maker, Intelligent closetool, Sweeping robot, Dish-washing Machine, Cooker hood, Electric lock.
- Hair Care: Hair Curler, Massager, Electric Hair Clipper
- Office Equipment: Shredder, Printer, Projector, Counting Machine
- Medical Equipment: Massage chair, Electric trolley, Medical pump, Electric bed, Electric wheelchair
- Industrial Equipment: Water, electrical and gas valve, Air switch, Pump, Automatic door, Automatic lubrication equipment.
- Business Equipment: Vending machines, Parking locks, ATM machines, Stage lights.
- Intelligent Robot: Mechanical Arm, UAV(Unmanned Aerial Vehicle), Service Robot

Outline Dimension

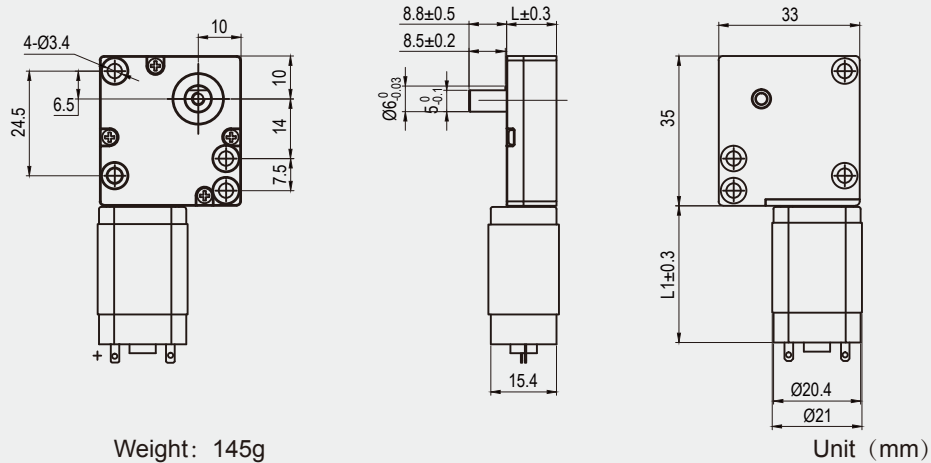

Voltage, rated torque, speed, current, power and shaft size can be customized as requirement.

Technical Data

MODEL	VOLTAGE V	NO-LOAD		AT MAXIMUM EFFICIENCY				STALL TORQUE			GEAR RATIO	LENGTH OF GEAR BOX(L) mm	MATCH THE MOTOR	LENGTH OF MOTOR(L1) mm	
		SPEED r/min	CURRENT A	SPEED r/min	CURRENT A	TORQUE mN.m	OUTPUT Kg.cm	TORQUE W	TORQUE mN.m	CURRENT Kg.cm					
JL-33Z180-117	12	100	0.11	83.3	0.3	0.1	1.20	1.16	0.6	6.20	1.7	117	33	JFF/K-180	32.1
JL-33Z180-235	12	41	0.07	32.7	0.43	0.3	3.45	1.16	1.6	16.00	1.9	235	33	JFF/K-180	32.1

Packing Details

QTY: 80pcs/ctn Carton Size: 40.5*28*25 cm Gross Weight: 13 kg/ctn Net Weight: 12 kg/ctn



Typical Applications

- Household Appliances: Electric curtain, Intergrated cooker, Coffee maker, Intelligent closetool, Sweeping robot, Dish-washing Machine, Cooker hood, Electric lock.
- Hair Care: Hair Curler, Massager, Electric Hair Clipper
- Office Equipment: Shredder, Printer, Projector, Counting Machine
- Medical Equipment: Massage chair, Electric trolley, Medical pump, Electric bed, Electric wheelchair
- Industrial Equipment: Water, electrical and gas valve, Air switch, Pump, Automatic door, Automatic lubrication equipment.
- Business Equipment: Vending machines, Parking locks, ATM machines, Stage lights.
- Intelligent Robot: Mechanical Arm, UAV(Unmanned Aerial Vehicle), Service Robot

Outline Dimension

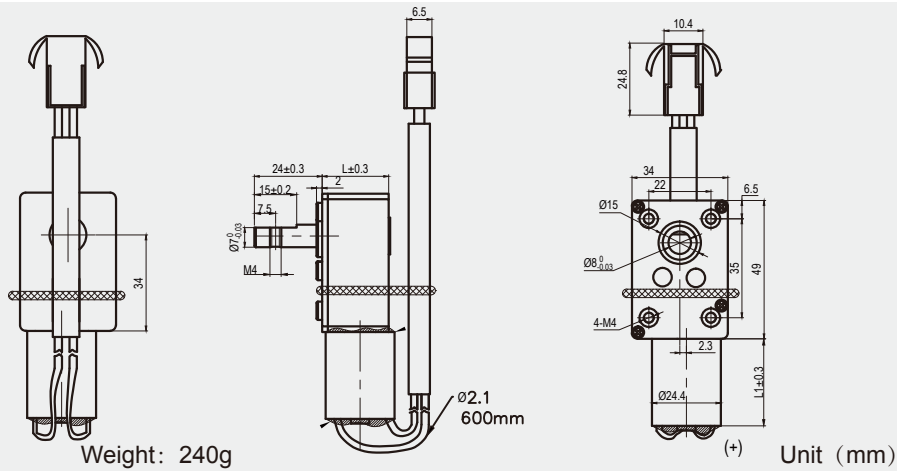

Voltage, rated torque, speed, current, power and shaft size can be customized as requirement.

Technical Data

MODEL	VOLTAGE		NO- LOAD		AT MAXIMUM EFFICIENCY					STALL		
	OPERATING RANGE	NOMINAL	SPEED	CURRENT	SPEED	CURRENT	TORQUE		OUTPUT	TORQUE		CURRENT
			r/min	A	r/min	A	mN.m	g.cm	W	mN.m	g.cm	A
JRB-3540D-018110P0	8-24V	DC24V	2200	0.10	1760	0.90	11.3	114.6	5.47	83.5	850.0	3.50
JRB-3540D-045014P0	8-24V	DC12V	7200	0.50	5760	1.38	21.4	218.0	12.54	220.0	1108.4	3.80
JRB-3540D-031035P0	8-24V	DC12V	4500	0.19	3600	0.55	13.2	134.4	3.38	53.9	549.2	3.50
JRB-3540D-028035P0	8-24V	DC24V	9500	0.25	7600	0.80	13.7	139.8	10.80	68.6	699.0	3.50
JRB-3540D-028028P0	8-24V	DC12V	6000	0.23	4770	0.65	9.5	96.9	6.60	52.6	535.8	3.50

Packing Details

QTY: 80pcs/ctn Carton Size: 40.5*28*25 cm Gross Weight: 14 kg/ctn Net Weight: 13.5 kg/ctn



Typical Applications

- Household Appliances: Electric curtain, Intergrated cooker, Coffee maker, Intelligent closetool, Sweeping robot, Dish-washing Machine, Cooker hood, Electric lock.
- Hair Care: Hair Curler, Massager, Electric Hair Clipper
- Office Equipment: Shredder, Printer, Projector, Counting Machine
- Medical Equipment: Massage chair, Electric trolley, Medical pump, Electric bed, Electric wheelchair
- Industrial Equipment: Water, electrical and gas valve, Air switch, Pump, Automatic door, Automatic lubrication equipment.
- Business Equipment: Vending machines, Parking locks, ATM machines, Stage lights.
- Intelligent Robot: Mechanical Arm, UAV (Unmanned Aerial Vehicle), Service Robot

Outline Dimension

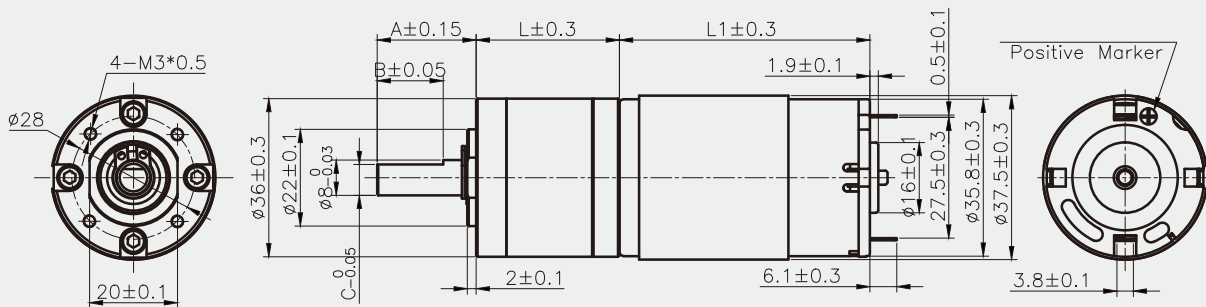

Weight: 500g

Unit (mm)

Voltage, rated torque, speed, current, power and shaft size can be customized as requirement.

Technical Data

MODEL	VOLTAGE	NO-LOAD		AT MAXIMUM EFFICIENCY				STALL TORQUE			GEAR RATIO	LENGTH OF GEAR BOX(L)	MATCH THE MOTOR	LENGTH OF MOTOR(L1)
		SPEED	CURRENT	SPEED	CURRENT	TORQUE		TORQUE	CURRENT					
		r/min	A	r/min	A	mN.m	Kg.cm	mN.m	Kg.cm	A				
JL-36P555-4	12	1097	0.43	842	1.45	101.5	1.03	446.2	4.55	4.93	4	39	JRK-555	57
JL-36P555-5	12	877	0.43	673	1.45	126.8	1.29	557.7	5.69	4.93	5	39	JRK-555	57
JL-36P555-14	12	313	0.43	240	1.45	355.1	3.62	1561.7	15.92	4.93	14	39	JRK-555	57
JL-36P555-19	12	231	0.43	177	1.45	481.9	4.91	2119.4	21.61	4.93	19	39	JRK-555	57
JL-36P555-27	12	162	0.43	125	1.45	684.8	6.98	3011.8	30.71	4.93	27	39	JRK-555	57
JL-36P555-51	12	86	0.48	66	1.61	1293.6	13.19	4527.6	46.17	4.93	51	39	JRK-555	57
JL-36P555-71	12	62	0.48	47	1.61	1800.8	18.36	5402.4	55.09	4.93	71	39	JRK-555	57
JL-36P555-100	12	44	0.48	34	1.61	2536.4	25.86	7609.2	77.59	4.93	100	39	JRK-555	57
JL-36P555-189	12	23	0.54	18	1.81	3046.5	31.07	9139.5	93.20	4.93	189	45.2	JRK-555	57
JL-36P555-263	12	17	0.54	13	1.81	3569.3	36.40	10708.8	109.20	4.93	263	45.2	JRK-555	57
JL-36P555-370	12	12	0.54	9	1.81	4025.4	41.05	12760.2	130.12	4.93	370	45.2	JRK-555	57
JL-36P555-514	12	9	0.61	7	2.07	4575.8	46.66	13727.4	139.98	4.93	514	45.2	JRK-555	57
JL-36P555-720	12	6	0.61	5	2.07	4958.6	50.56	14875.8	151.69	4.93	720	45.2	JRK-555	57

Packing Details

QTY: 40pcs/ctn Carton Size: 40.5*28*25 cm Gross Weight: 21 kg/ctn Net Weight: 20 kg/ctn



Typical Applications

- Household Appliances: Electric curtain, Intergrated cooker, Coffee maker, Intelligent closetool, Sweeping robot, Dish-washing Machine, Cooker hood, Electric lock.
- Hair Care: Hair Curler, Massager, Electric Hair Clipper
- Office Equipment: Shredder, Printer, Projector, Counting Machine
- Medical Equipment: Massage chair, Electric trolley, Medical pump, Electric bed, Electric wheelchair
- Industrial Equipment: Water, electrical and gas valve, Air switch, Pump, Automatic door, Automatic lubrication equipment.
- Business Equipment: Vending machines, Parking locks, ATM machines, Stage lights.
- Intelligent Robot: Mechanical Arm, UAV(Unmanned Aerial Vehicle), Service Robot

Outline Dimension

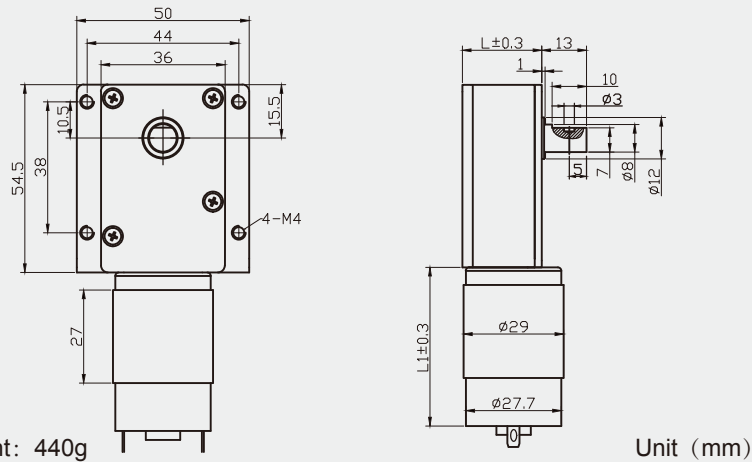

Voltage, rated torque, speed, current, power and shaft size can be customized as requirement.

Technical Data

MODEL	VOLTAGE V	NO- LOAD		AT MAXIMUM EFFICIENCY				STALL TORQUE			GEAR RATIO	LENGTH OF GEAR BOX(L)	MATCH THE MOTOR	LENGTH OF MOTOR(L1) mm
		SPEED r/min	CURRENT A	SPEED r/min	CURRENT A	TORQUE		TORQUE mN.m	TORQUE Kg.cm	CURRENT A				
						mN.m	Kg.cm							
JL-36Z395-68	24	124	0.095	106	0.53	309.7	3.16	2041.0	20.81	2.97	68	23	JRS-395	46
JL-36Z395-113	24	75	0.095	64	0.53	514.7	5.25	3391.7	34.58	2.97	113	23	JRS-395	46
JL-36Z395-133	24	63	0.095	54	0.53	605.8	6.18	3992.0	40.71	2.97	133	23	JRS-395	46
JL-36Z395-155	24	54	0.095	47	0.53	706.0	7.20	4652.3	47.44	2.97	155	23	JRS-395	46
JL-36Z395-225	24	37	0.095	32	0.53	1024.8	10.45	6753.3	68.86	2.97	225	23	JRS-395	46
JL-36Z395-310	24	27	0.095	23	0.53	1412.0	14.40	9304.6	94.88	2.97	310	23	JRS-395	46

Packing Details

QTY: 40pcs/ctn Carton Size: 85*39.5*29.5 cm Gross Weight: 22 kg/ctn Net Weight: 21 kg/ctn



Typical Applications

- Household Appliances: Electric curtain, Intergrated cooker, Coffee maker, Intelligent closetool, Sweeping robot, Dish-washing Machine, Cooker hood, Electric lock.
- Hair Care: Hair Curler, Massager, Electric Hair Clipper
- Office Equipment: Shredder, Printer, Projector, Counting Machine
- Medical Equipment: Massage chair, Electric trolley, Medical pump, Electric bed, Electric wheelchair
- Industrial Equipment: Water, electrical and gas valve, Air switch, Pump, Automatic door, Automatic lubrication equipment.
- Business Equipment: Vending machines, Parking locks, ATM machines, Stage lights.
- Intelligent Robot: Mechanical Arm, UAV (Unmanned Aerial Vehicle), Service Robot

Outline Dimension

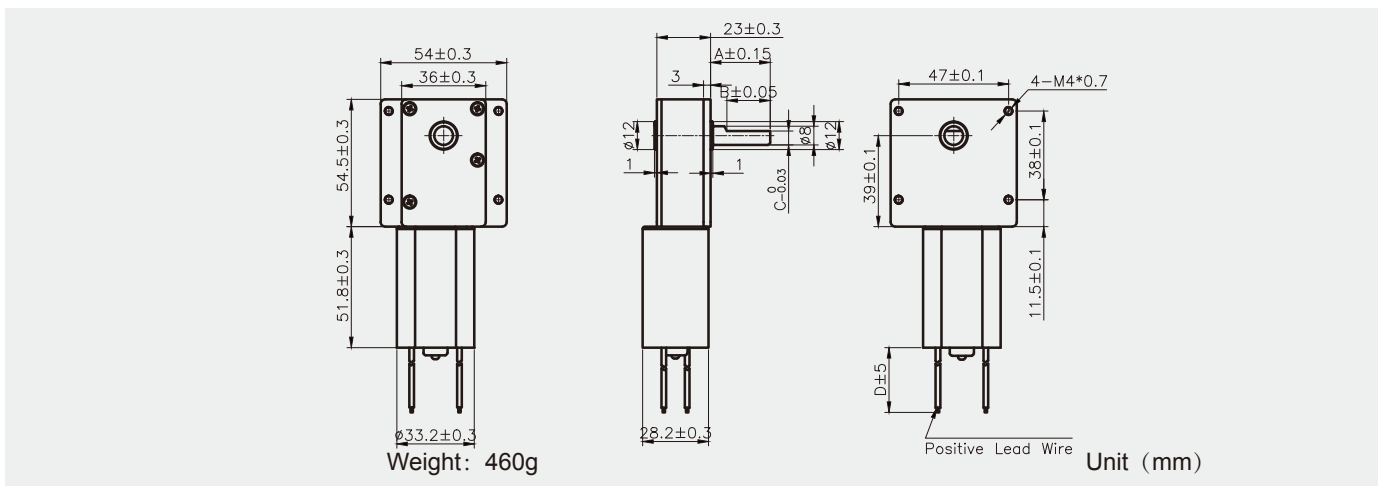

Voltage, rated torque, speed, current, power and shaft size can be customized as requirement.

Technical Data

MODEL	VOLTAGE	NO- LOAD		AT MAXIMUM EFFICIENCY				STALL TORQUE			GEAR RATIO	LENGTH OF GEAR BOX(L)	MATCH THE MOTOR	LENGTH OF MOTOR(L1)
		SPEED	CURRENT	SPEED	CURRENT	TORQUE		TORQUE	CURRENT					
		r/min	A	r/min	A	mN.m	Kg.cm	mN.m	Kg.cm	A				
JL-36Z5508-68	12	27	0.1	18	0.26	318.9	3.25	1147.0	11.70	0.67	68	23	JFK-5508	51.8
JL-36Z5508-113	12	16	0.1	11	0.26	529.9	5.40	1906.1	19.44	0.67	113	23	JFK-5508	51.8
JL-36Z5508-136	12	14	0.1	9	0.26	623.7	6.36	2243.4	22.88	0.67	133	23	JFK-5508	51.8
JL-36Z5508-155	12	12	0.1	8	0.26	726.9	7.41	2614.5	26.66	0.67	155	23	JFK-5508	51.8
JL-36Z5508-225	12	8	0.1	6	0.26	1055.2	10.76	3795.2	38.70	0.67	225	23	JFK-5508	51.8
JL-36Z5508-310	12	6	0.1	4	0.26	1453.8	14.82	5229.0	53.32	0.67	310	23	JFK-5508	51.8

Packing Details

QTY: 40pcs/ctn Carton Size: 85*39.5*29.5 cm Gross Weight: 22 kg/ctn Net Weight: 21 kg/ctn



Typical Applications

- Household Appliances: Electric curtain, Intergrated cooker, Coffee maker, Intelligent closetool, Sweeping robot, Dish-washing Machine, Cooker hood, Electric lock.
- Hair Care: Hair Curler, Massager, Electric Hair Clipper
- Office Equipment: Shredder, Printer, Projector, Counting Machine
- Medical Equipment: Massage chair, Electric trolley, Medical pump, Electric bed, Electric wheelchair
- Industrial Equipment: Water, electrical and gas valve, Air switch, Pump, Automatic door, Automatic lubrication equipment.
- Business Equipment: Vending machines, Parking locks, ATM machines, Stage lights.
- Intelligent Robot: Mechanical Arm, UAV (Unmanned Aerial Vehicle), Service Robot

Outline Dimension

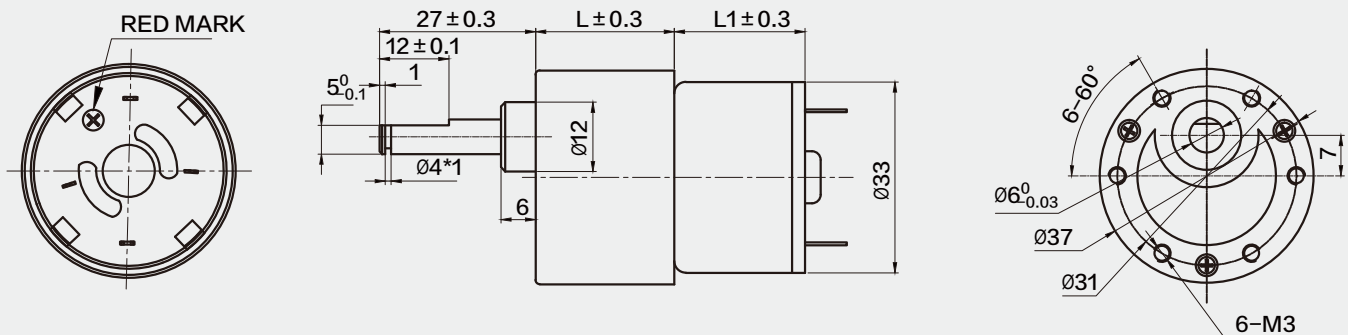

Weight: 180g

Unit (mm)

Voltage, rated torque, speed, current, power and shaft size can be customized as requirement.

Technical Data

MODEL	VOLTAGE	NO-LOAD		AT MAXIMUM EFFICIENCY			STALL TORQUE			GEAR RATIO	LENGTH OF GEAR BOX (L)	MATCH THE MOTOR	LENGTH OF MOTOR (L1)	
		SPEED	CURRENT	SPEED	CURRENT	TORQUE	TORQUE	CURRENT						
	V	r/min	A	r/min	A	mN.m	Kg.cm	mN.m	Kg.cm	A	mm	mm		
JL-37B520-5	12	1100	0.040	940	0.18	14.7	0.15	300.0	0.62	1.6	5	21	JRF/K-520	22.6
JL-37B520-10	12	550	0.040	470	0.18	29.4	0.30	600.0	0.72	1.6	10	21	JRF/K-520	22.6
JL-37B520-20	12	275	0.040	235	0.18	58.8	0.60	1200.0	1.44	1.6	20	21	JRF/K-520	22.6
JL-37B520-30	12	183	0.040	157	0.18	105.2	1.07	2140.0	2.56	1.6	30	21	JRF/K-520	22.6
JL-37B520-40	12	138	0.040	118	0.18	105.2	1.07	2140.0	2.56	1.6	40	21	JRF/K-520	22.6
JL-37B520-50	12	110	0.040	94	0.18	136.4	1.39	2780.0	3.33	1.6	50	21	JRF/K-520	22.6
JL-37B520-60	12	92	0.044	78	0.20	180.5	1.84	3680.0	4.40	1.6	60	21	JRF/K-520	22.6
JL-37B520-70	12	79	0.044	67	0.20	201.5	2.05	4100.0	4.91	1.6	70	21	JRF/K-520	22.6
JL-37B520-90	12	61	0.044	52	0.20	243.5	2.48	4960.0	5.94	1.6	90	21	JRF/K-520	22.6
JL-37B520-120	12	46	0.044	39	0.20	280.3	2.86	5720.0	6.85	1.6	120	24	JRF/K-520	22.6
JL-37B520-150	12	37	0.044	31	0.20	320.5	3.27	6540.0	7.83	1.6	150	24	JRF/K-520	22.6
JL-37B520-210	12	26	0.050	22	0.23	350.4	3.57	7140.0	8.55	1.6	210	24	JRF/K-520	22.6
JL-37B520-450	12	12	0.050	10	0.23	650.4	6.63	9945.0	11.90	1.6	450	26.5	JRF/K-520	22.6
JL-37B520-540	12	10	0.050	9	0.23	750.5	7.65	11470.5	13.73	1.6	540	26.5	JRF/K-520	22.6
JL-37B520-630	12	9	0.050	7	0.23	820.5	8.37	12555.0	15.03	1.6	630	26.5	JRF/K-520	22.6
JL-37B520-810	12	7	0.050	6	0.23	902.5	9.20	13800.0	16.52	1.6	810	26.5	JRF/K-520	22.6
JL-37B520-1069	12	5	0.057	4	0.26	1025.0	10.45	15675.0	18.76	1.6	1069	26.5	JRF/K-520	22.6

Packing Details

QTY: 80pcs/ctn Carton Size: 40.5*28*25 cm Gross Weight: .22 kg/ctn Net Weight: 21 kg/ctn



Typical Applications

- Household Appliances: Electric curtain, Intergrated cooker, Coffee maker, Intelligent closetool, Sweeping robot, Dish-washing Machine, Cooker hood, Electric lock.
- Hair Care: Hair Curler, Massager, Electric Hair Clipper
- Office Equipment: Shredder, Printer, Projector, Counting Machine
- Medical Equipment: Massage chair, Electric trolley, Medical pump, Electric bed, Electric wheelchair
- Industrial Equipment: Water, electrical and gas valve, Air switch, Pump, Automatic door, Automatic lubrication equipment.
- Business Equipment: Vending machines, Parking locks, ATM machines, Stage lights.
- Intelligent Robot: Mechanical Arm, UAV (Unmanned Aerial Vehicle), Service Robot

Outline Dimension

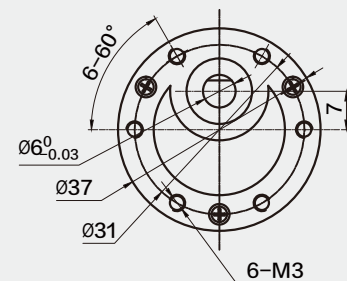
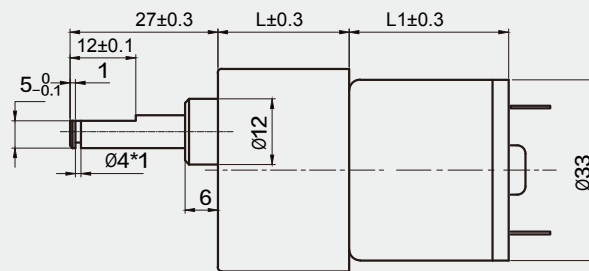
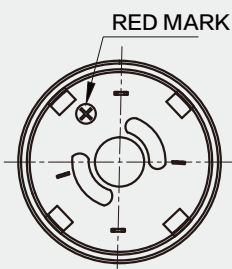

Weight: 190g

Unit (mm)

Voltage, rated torque, speed, current, power and shaft size can be customized as requirement.

Technical Data

MODEL	VOLTAGE	NO- LOAD		AT MAXIMUM EFFICIENCY				STALL TORQUE			GEAR RATIO	LENGTH OF GEAR BOX(L)	MATCH THE MOTOR	LENGTH OF MOTOR(L1)
		SPEED	CURRENT	SPEED	CURRENT	TORQUE		TORQUE	CURRENT					
						r/min	A			mN.m				
V	r/min	A	r/min	A	mN.m	Kg.cm	mN.m	Kg.cm	A	mm	mm			
JL-37B528-5	12	1386	0.070	1116	0.32	17.4	0.18	89.3	0.91	1.7	5	21	JRF/K-528	30.1
JL-37B528-10	12	693	0.070	558	0.32	34.9	0.36	178.6	1.82	1.7	10	21	JRF/K-528	30.1
JL-37B528-20	12	347	0.070	279	0.32	69.8	0.71	209.4	2.14	1.7	20	21	JRF/K-528	30.1
JL-37B528-30	12	231	0.070	186	0.32	104.7	1.07	261.8	2.67	1.7	30	21	JRF/K-528	30.1
JL-37B528-40	12	173	0.070	140	0.32	139.6	1.42	490.0	5.00	1.7	40	21	JRF/K-528	30.1
JL-37B528-50	12	139	0.070	112	0.32	174.4	1.78	588.6	6.00	1.7	50	21	JRF/K-528	30.1
JL-37B528-60	12	116	0.078	93	0.36	209.3	2.13	669.8	6.83	1.7	60	21	JRF/K-528	30.1
JL-37B528-70	12	99	0.078	80	0.36	244.2	2.49	781.4	7.97	1.7	70	21	JRF/K-528	30.1
JL-37B528-90	12	77	0.078	62	0.36	314.0	3.20	990.0	10.10	1.7	90	21	JRF/K-528	30.1
JL-37B528-120	12	58	0.078	47	0.36	418.7	4.27	1260.0	12.85	1.7	120	24	JRF/K-528	30.1
JL-37B528-150	12	46	0.078	37	0.36	523.3	5.34	1495.2	15.25	1.7	150	24	JRF/K-528	30.1
JL-37B528-210	12	33	0.088	27	0.40	732.7	7.47	1850.2	18.87	1.7	210	24	JRF/K-528	30.1
JL-37B528-270	12	26	0.088	21	0.40	824.5	8.41	2100.0	21.41	1.7	270	24	JRF/K-528	30.1
JL-37B528-450	12	15	0.088	12	0.40	900.5	9.18	2295.0	23.40	1.7	450	26.5	JRF/K-528	30.1
JL-37B528-540	12	13	0.088	10	0.40	1005.4	10.25	2350.3	23.97	1.7	540	26.5	JRF/K-528	30.1
JL-37B528-630	12	11	0.088	9	0.40	1125.5	11.48	2562.5	26.13	1.7	630	26.5	JRF/K-528	30.1
JL-37B528-810	12	9	0.088	7	0.40	1252.4	12.77	2937.1	29.95	1.7	810	26.5	JRF/K-528	30.1
JL-37B528-1069	12	6	0.100	5	0.46	1425.6	14.54	3135.6	31.97	1.7	1069	26.5	JRF/K-528	30.1

Packing Details

QTY: 80pcs/ctn Carton Size: 40.5*28*25 cm Gross Weight: .22 kg/ctn Net Weight: 21 kg/ctn



Typical Applications

- Household Appliances: Electric curtain, Intergrated cooker, Coffee maker, Intelligent closetool, Sweeping robot, Dish-washing Machine, Cooker hood, Electric lock.
- Hair Care: Hair Curler, Massager, Electric Hair Clipper
- Office Equipment: Shredder, Printer, Projector, Counting Machine
- Medical Equipment: Massage chair, Electric trolley, Medical pump, Electric bed, Electric wheelchair
- Industrial Equipment: Water, electrical and gas valve, Air switch, Pump, Automatic door, Automatic lubrication equipment.
- Business Equipment: Vending machines, Parking locks, ATM machines, Stage lights.
- Intelligent Robot: Mechanical Arm, UAV (Unmanned Aerial Vehicle), Service Robot

Outline Dimension

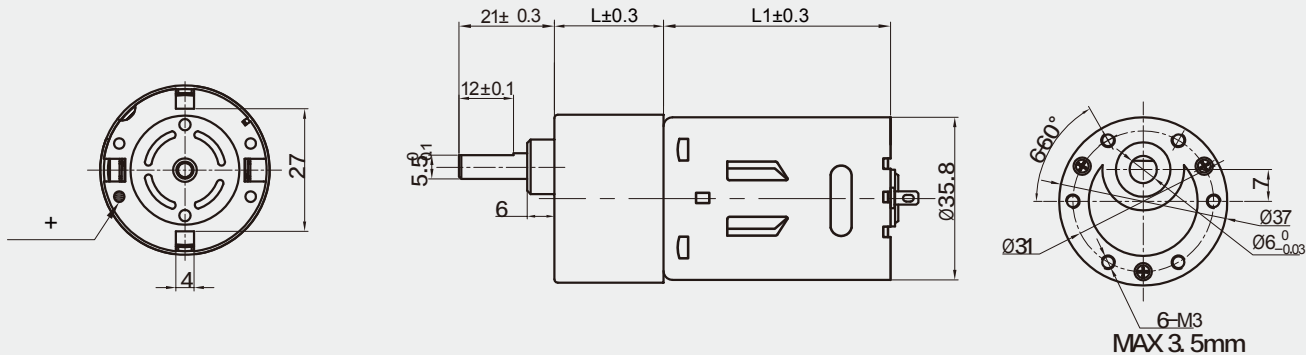

Weight: 200g

Unit (mm)

Voltage, rated torque, speed, current, power and shaft size can be customized as requirement.

Technical Data

MODEL	VOLTAGE	NO-LOAD		AT MAXIMUM EFFICIENCY			STALL TORQUE			GEAR RATIO	LENGTH OF GEAR BOX(L)	MATCH THE MOTOR	LENGTH OF MOTOR(L1)	
		SPEED	CURRENT	SPEED	CURRENT	TORQUE	TORQUE	CURRENT						
	V	r/min	A	r/min	A	mN.m	Kg.cm	mN.m	Kg.cm	A	mm		mm	
JL-37B545-5	24	1104	0.150	912	0.550	55.2	0.56	220.8	2.25	2.3	5	21	JRK-545	50
JL-37B545-10	24	552	0.150	456	0.550	75.2	0.77	300.8	3.07	2.3	10	21	JRK-545	50
JL-37B545-20	24	276	0.150	228	0.550	85.5	0.87	342.0	3.42	2.3	20	21	JRK-545	50
JL-37B545-30	24	184	0.150	152	0.550	95.6	0.97	382.4	3.90	2.3	30	21	JRK-545	50
JL-37B545-40	24	138	0.150	114	0.550	102.0	1.04	459.2	4.68	2.3	40	21	JRK-545	50
JL-37B545-50	24	110	0.150	91	0.550	120.2	1.23	601.0	6.13	2.3	50	21	JRK-545	50
JL-37B545-60	24	92	0.167	76	0.611	202.0	2.06	808.2	8.24	2.3	60	21	JRK-545	50
JL-37B545-70	24	79	0.167	65	0.611	250.2	2.55	905.6	9.23	2.3	70	21	JRK-545	50
JL-37B545-90	24	61	0.167	51	0.611	450.4	4.59	1005.2	10.25	2.3	90	21	JRK-545	50
JL-37B545-120	24	46	0.167	38	0.611	650.0	6.63	1300.2	13.26	2.3	120	24	JRK-545	50
JL-37B545-150	24	37	0.167	30	0.611	750.8	7.66	1501.6	15.31	2.3	150	24	JRK-545	50
JL-37B545-210	24	26	0.188	22	0.688	850.5	8.67	1701.5	17.35	2.3	210	24	JRK-545	50
JL-37B545-270	24	20	0.188	17	0.688	940.2	9.59	1880.4	19.17	2.3	270	24	JRK-545	50
JL-37B545-450	24	12	0.188	10	0.688	1005.5	10.25	2011.5	20.51	2.3	450	26.5	JRK-545	50
JL-37B545-540	24	10	0.188	8	0.688	1105.8	11.28	2211.6	22.55	2.3	540	26.5	JRK-545	50
JL-37B545-630	24	9	0.188	7	0.688	1258.4	12.83	3146.2	32.08	2.3	630	26.5	JRK-545	50
JL-37B545-810	24	7	0.188	6	0.688	1380.5	14.08	3451.3	35.19	2.3	810	26.5	JRK-545	50
JL-37B545-1069	24	5	0.214	4	0.786	1595.8	16.27	3989.5	40.68	2.3	1069	26.5	JRK-545	50

Packing Details

QTY: 80pcs/ctn Carton Size: 40.5*28*25 cm Gross Weight: .22 kg/ctn Net Weight: 21 kg/ctn



Typical Applications

- Household Appliances: Electric curtain, Intergrated cooker, Coffee maker, Intelligent closetool, Sweeping robot, Dish-washing Machine, Cooker hood, Electric lock.
- Hair Care: Hair Curler, Massager, Electric Hair Clipper
- Office Equipment: Shredder, Printer, Projector, Counting Machine
- Medical Equipment: Massage chair, Electric trolley, Medical pump, Electric bed, Electric wheelchair
- Industrial Equipment: Water, electrical and gas valve, Air switch, Pump, Automatic door, Automatic lubrication equipment.
- Business Equipment: Vending machines, Parking locks, ATM machines, Stage lights.
- Intelligent Robot: Mechanical Arm, UAV (Unmanned Aerial Vehicle), Service Robot

Outline Dimension

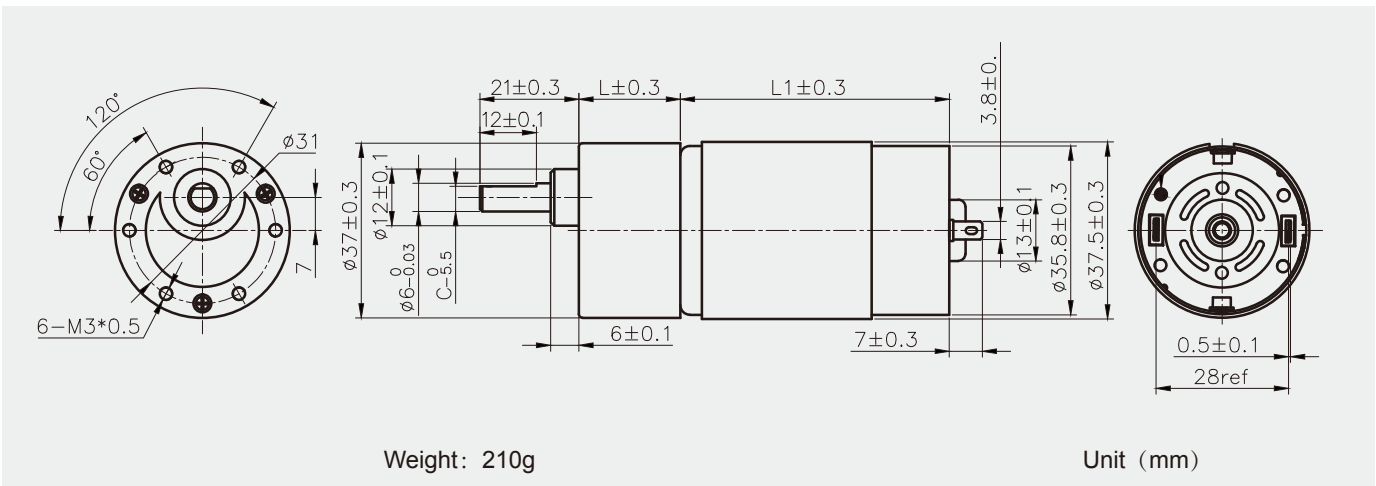

Voltage, rated torque, speed, current, power and shaft size can be customized as requirement.

Technical Data

MODEL	VOLTAGE	NO-LOAD		AT MAXIMUM EFFICIENCY				STALL TORQUE			GEAR RATIO	LENGTH OF GEAR BOX (L)	MATCH THE MOTOR	LENGTH OF MOTOR (L1)
		SPEED	CURRENT	SPEED	CURRENT	TORQUE		TORQUE	CURRENT					
						mN.m	Kg.cm			mN.m				
JL-37B555-5	12	660	0.190	576	1.060	80.0	0.82	320.0	3.26	7	5	21.5	JRK-555	57
JL-37B555-10	12	330	0.190	288	1.060	100.2	1.02	400.2	4.08	7	10	21.5	JRK-555	57
JL-37B555-20	12	165	0.190	144	1.060	150.4	1.53	526.4	5.37	7	20	21.5	JRK-555	57
JL-37B555-30	12	110	0.190	96	1.060	210.5	2.15	688.2	7.02	7	30	21.5	JRK-555	57
JL-37B555-40	12	83	0.190	72	1.060	350.2	3.57	875.2	8.92	7	40	21.5	JRK-555	57
JL-37B555-50	12	66	0.190	58	1.060	380.6	3.88	950.2	9.69	7	50	21.5	JRK-555	57
JL-37B555-60	12	55	0.211	48	1.178	420.8	4.29	1158.2	11.81	7	60	21.5	JRK-555	57
JL-37B555-70	12	47	0.211	41	1.178	485.9	4.95	1342.6	13.69	7	70	21.5	JRK-555	57
JL-37B555-90	12	37	0.211	32	1.178	630.5	6.43	1472.9	15.02	7	90	21.5	JRK-555	57
JL-37B555-120	12	28	0.211	24	1.178	720.5	7.35	1911.5	19.49	7	120	24	JRK-555	57
JL-37B555-150	12	22	0.211	19	1.178	825.6	8.42	2150.2	21.93	7	150	24	JRK-555	57
JL-37B555-210	12	16	0.238	14	1.325	950.2	9.69	2435.4	24.83	7	210	24	JRK-555	57
JL-37B555-270	12	12	0.238	10.67	1.325	1050.0	10.71	2765.8	28.20	7	270	24	JRK-555	57
JL-37B555-450	12	7	0.238	6.40	1.325	1145.4	11.68	2958.9	30.17	7	450	26.5	JRK-555	57
JL-37B555-540	12	6	0.238	5.33	1.325	1320.5	13.47	3367.5	34.34	7	540	26.5	JRK-555	57
JL-37B555-630	12	5	0.238	4.57	1.325	1450.2	14.79	3697.5	37.70	7	630	26.5	JRK-555	57
JL-37B555-810	12	4	0.238	3.56	1.325	1550.6	15.81	3952.5	40.30	7	810	26.5	JRK-555	57
JL-37B555-1069	12	3	0.271	2.69	1.514	1650.8	16.83	4207.5	42.90	7	1069	26.5	JRK-555	57

Packing Details

QTY: 80pcs/ctn Carton Size: 40.5*28*25 cm Gross Weight: .22 kg/ctn Net Weight: 21 kg/ctn



Typical Applications

- Household Appliances: Electric curtain, Intergrated cooker, Coffee maker, Intelligent closetool, Sweeping robot, Dish-washing Machine, Cooker hood, Electric lock.
- Hair Care: Hair Curler, Massager, Electric Hair Clipper
- Office Equipment: Shredder, Printer, Projector, Counting Machine
- Medical Equipment: Massage chair, Electric trolley, Medical pump, Electric bed, Electric wheelchair
- Industrial Equipment: Water, electrical and gas valve, Air switch, Pump, Automatic door, Automatic lubrication equipment.
- Business Equipment: Vending machines, Parking locks, ATM machines, Stage lights.
- Intelligent Robot: Mechanical Arm, UAV (Unmanned Aerial Vehicle), Service Robot

Outline Dimension

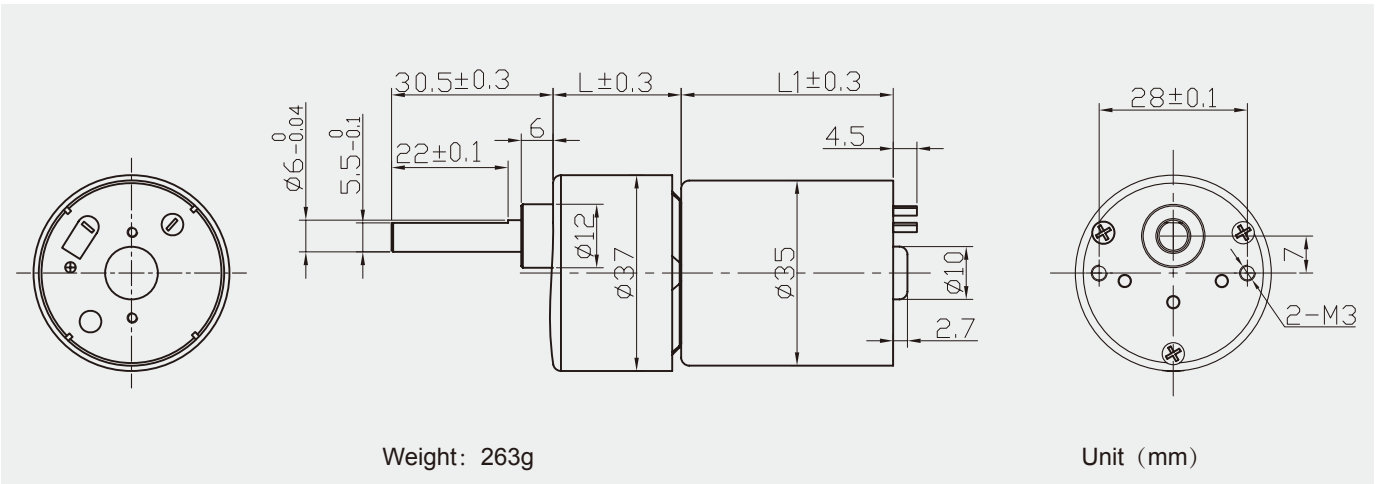

Voltage, rated torque, speed, current, power and shaft size can be customized as requirement.

Technical Data

MODEL	VOLTAGE V	NO-LOAD		AT MAXIMUM EFFICIENCY				STALL TORQUE			GEAR RATIO	LENGTH OF GEAR BOX (L) mm	MATCH THE MOTOR	LENGTH OF MOTOR (L1) mm
		SPEED r/min	CURRENT A	SPEED r/min	CURRENT A	TORQUE mN.m Kg.cm		TORQUE mN.m Kg.cm	CURRENT A					
JL-37C3540-52	12	213	0.24	167	1.9	661.8	6.75	3186.3	32.49	12	52	24.2	JRK-3540	40
JL-37C3540-72.8	12	152	0.24	119	1.9	926.5	9.45	4460.8	45.50	12	72.8	24.2	JRK-3540	40

Packing Details

QTY: 80pcs/ctn Carton Size: 40.5*28*25 cm Gross Weight: .22 kg/ctn Net Weight: 21 kg/ctn



Typical Applications

- Household Appliances: Electric curtain, Intergrated cooker, Coffee maker, Intelligent closetool, Sweeping robot, Dish-washing Machine, Cooker hood, Electric lock.
- Hair Care: Hair Curler, Massager, Electric Hair Clipper
- Office Equipment: Shredder, Printer, Projector, Counting Machine
- Medical Equipment: Massage chair, Electric trolley, Medical pump, Electric bed, Electric wheelchair
- Industrial Equipment: Water, electrical and gas valve, Air switch, Pump, Automatic door, Automatic lubrication equipment.
- Business Equipment: Vending machines, Parking locks, ATM machines, Stage lights.
- Intelligent Robot: Mechanical Arm, UAV (Unmanned Aerial Vehicle), Service Robot

Outline Dimension

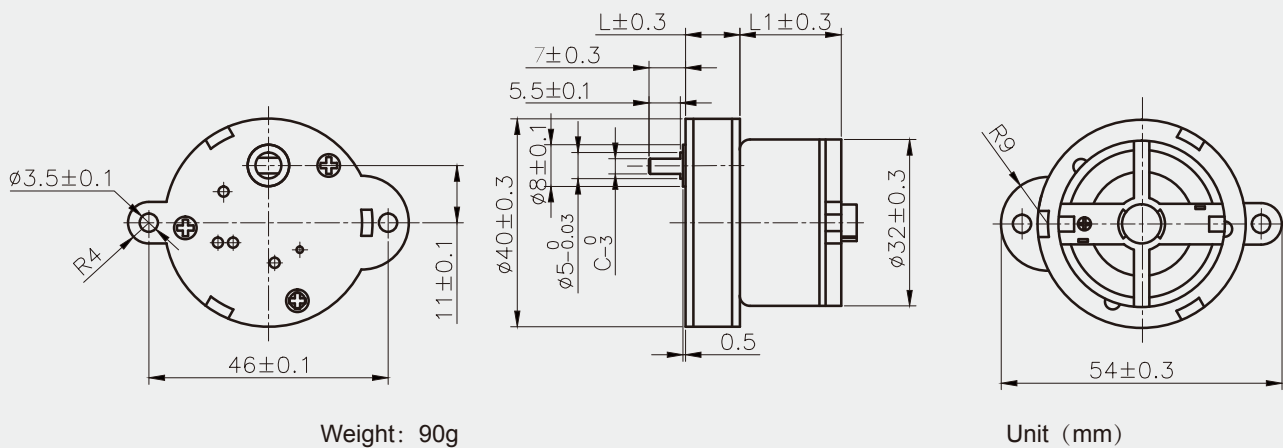

Voltage, rated torque, speed, current, power and shaft size can be customized as requirement.

Technical Data

MODEL	VOLTAGE V	NO-LOAD		AT MAXIMUM EFFICIENCY				STALL TORQUE			GEAR RATIO	LENGTH OF GEAR BOX (L) mm	MATCH THE MOTOR	LENGTH OF MOTOR (L1) mm
		SPEED r/min	CURRENT A	SPEED r/min	CURRENT A	TORQUE		TORQUE	CURRENT					
						mN.m	Kg.cm	mN.m	Kg.cm	A				
JL-40B500-27	12	204	0.033	160	0.120	35.0	0.36	126.2	1.29	0.44	27	10.45	JRF/K-500	19.5
JL-40B500-40	12	138	0.033	108	0.120	51.8	0.53	185.5	1.89	0.44	40	10.45	JRF/K-500	19.5
JL-40B500-103	12	54	0.037	42	0.133	133.4	1.36	476.0	4.85	0.44	103	10.45	JRF/K-500	19.5
JL-40B500-390	12	14	0.041	11	0.150	305.8	3.12	1092.0	11.14	0.44	390	10.45	JRF/K-500	19.5
JL-40B520-27	12	273	0.107	212	0.370	70.5	0.72	252.3	2.57	1.28	27	10.45	JRF/K-520	23
JL-40B520-40	12	184	0.107	143	0.370	90.2	0.92	322.5	3.29	1.28	40	10.45	JRF/K-520	23
JL-40B520-103	12	72	0.119	56	0.411	205.3	2.09	731.5	7.46	1.28	103	10.45	JRF/K-520	23
JL-40B520-390	12	19	0.134	15	0.463	415.8	4.24	1065.3	10.86	1.28	390	10.45	JRF/K-520	23

Packing Details

QTY: 100pcs/ctn Carton Size: 36.5*26.5*24 cm Gross Weight: .9 kg/ctn Net Weight: 8.5 kg/ctn



Typical Applications

- Household Appliances: Electric curtain, Intergrated cooker, Coffee maker, Intelligent closetool, Sweeping robot, Dish-washing Machine, Cooker hood, Electric lock.
- Hair Care: Hair Curler, Massager, Electric Hair Clipper
- Office Equipment: Shredder, Printer, Projector, Counting Machine
- Medical Equipment: Massage chair, Electric trolley, Medical pump, Electric bed, Electric wheelchair
- Industrial Equipment: Water, electrical and gas valve, Air switch, Pump, Automatic door, Automatic lubrication equipment.
- Business Equipment: Vending machines, Parking locks, ATM machines, Stage lights.
- Intelligent Robot: Mechanical Arm, UAV (Unmanned Aerial Vehicle), Service Robot

Outline Dimension

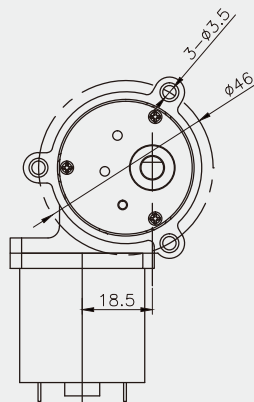

Weight: 300g

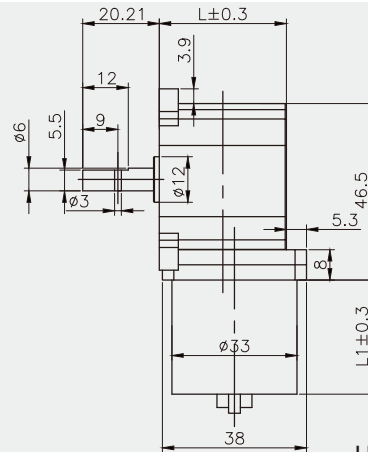

Unit (mm)

Voltage, rated torque, speed, current, power and shaft size can be customized as requirement.

Technical Data

MODEL	VOLTAGE	NO-LOAD		AT MAXIMUM EFFICIENCY			STALL TORQUE			GEAR RATIO	LENGTH OF GEAR BOX(L)	MATCH THE MOTOR	LENGTH OF MOTOR(L1)	
		SPEED	CURRENT	SPEED	CURRENT	TORQUE	TORQUE		CURRENT					
	V	r/min	A	r/min	A	mN.m	Kg.cm	mN.m	Kg.cm					A
JL-4058Z528-25	12	370	0.31	283.5	1.4	176.4	1.8	5.2	637	6.5	5.7	25	33.5	RK-528

Packing Details

TY: 60pcs/ctn Carton Size: 40.5*28*25 cm Gross Weight: 20 kg/ctn Net Weight: 19 kg/ctn



Typical Applications

- Household Appliances: Electric curtain, Intergrated cooker, Coffee maker, Intelligent closetool, Sweeping robot, Dish-washing Machine, Cooker hood, Electric lock.
- Hair Care: Hair Curler, Massager, Electric Hair Clipper
- Office Equipment: Shredder, Printer, Projector, Counting Machine
- Medical Equipment: Massage chair, Electric trolley, Medical pump, Electric bed, Electric wheelchair
- Industrial Equipment: Water, electrical and gas valve, Air switch, Pump, Automatic door, Automatic lubrication equipment.
- Business Equipment: Vending machines, Parking locks, ATM machines, Stage lights.
- Intelligent Robot: Mechanical Arm, UAV (Unmanned Aerial Vehicle), Service Robot

Outline Dimension

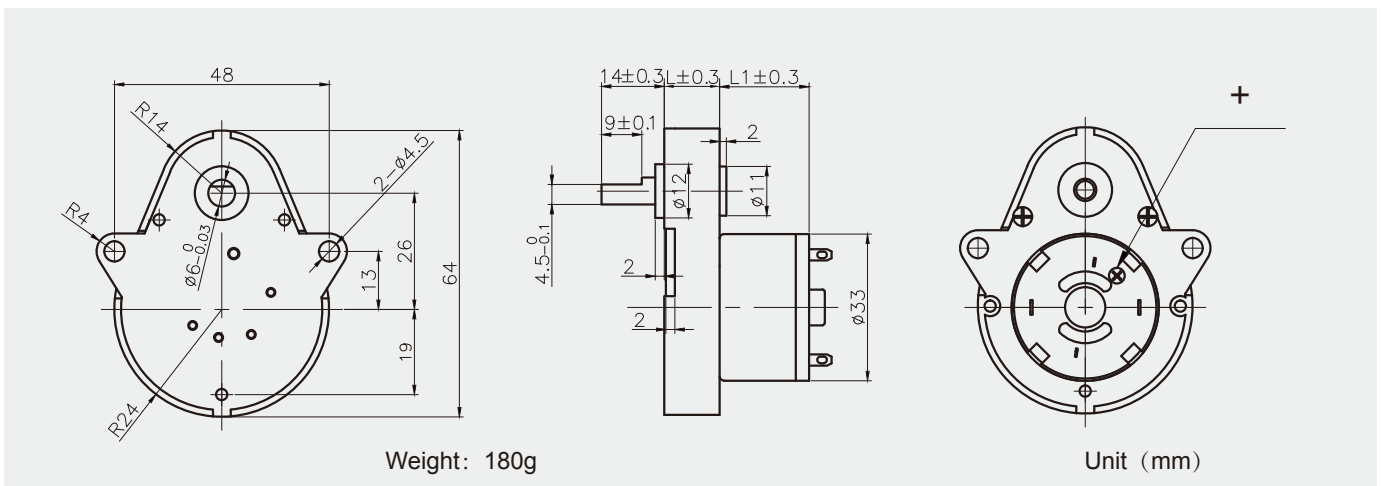

Voltage, rated torque, speed, current, power and shaft size can be customized as requirement.

Technical Data

MODEL	VOLTAGE	NO-LOAD		AT MAXIMUM EFFICIENCY				STALL TORQUE			GEAR RATIO	LENGTH OF GEAR BOX (L)	MATCH THE MOTOR	LENGTH OF MOTOR (L1)
		SPEED	CURRENT	SPEED	CURRENT	TORQUE		TORQUE	CURRENT					
		r/min	A	r/min	A	mN.m	Kg.cm	mN.m	Kg.cm	A				
V	r/min	A	r/min	A	mN.m	Kg.cm	mN.m	Kg.cm	A	mm	mm			
JL-48E520-30	12	288	0.095	223	0.35	77.8	0.79	311.3	3.17	1.27	30	12.4	JRF/K-520	23
JL-48E520-56	12	154	0.095	120	0.35	98.2	1.00	392.8	4.01	1.27	56	12.4	JRF/K-520	23
JL-48E520-75	12	115	0.095	89	0.35	102.5	1.05	410.0	4.18	1.27	75	12.4	JRF/K-520	23
JL-48E520-112	12	77	0.106	60	0.39	154.8	1.58	541.8	5.52	1.27	112	12.4	JRF/K-520	23
JL-48E520-160	12	54	0.106	42	0.39	305.3	3.11	933.2	9.52	1.27	160	12.4	JRF/K-520	23
JL-48E520-216	12	40	0.106	31	0.39	550.2	5.61	1375.5	14.03	1.27	216	12.4	JRF/K-520	23
JL-48E520-427	12	20	0.119	16	0.44	850.6	8.67	1701.2	17.35	1.27	427	12.4	JRF/K-520	23
JL-48E520-538	12	16	0.119	12	0.44	995.2	10.15	1990.4	20.30	1.27	538	12.4	JRF/K-520	23

Packing Details

QTY: 100pcs/ctn Carton Size: 33.5*32.8*26.8 cm Gross Weight: .18.5 kg/ctn Net Weight: 18 kg/ctn



Typical Applications

- Household Appliances: Electric curtain, Intergrated cooker, Coffee maker, Intelligent closetool, Sweeping robot, Dish-washing Machine, Cooker hood, Electric lock.
- Hair Care: Hair Curler, Massager, Electric Hair Clipper
- Office Equipment: Shredder, Printer, Projector, Counting Machine
- Medical Equipment: Massage chair, Electric trolley, Medical pump, Electric bed, Electric wheelchair
- Industrial Equipment: Water, electrical and gas valve, Air switch, Pump, Automatic door, Automatic lubrication equipment.
- Business Equipment: Vending machines, Parking locks, ATM machines, Stage lights.
- Intelligent Robot: Mechanical Arm, UAV (Unmanned Aerial Vehicle), Service Robot

Outline Dimension

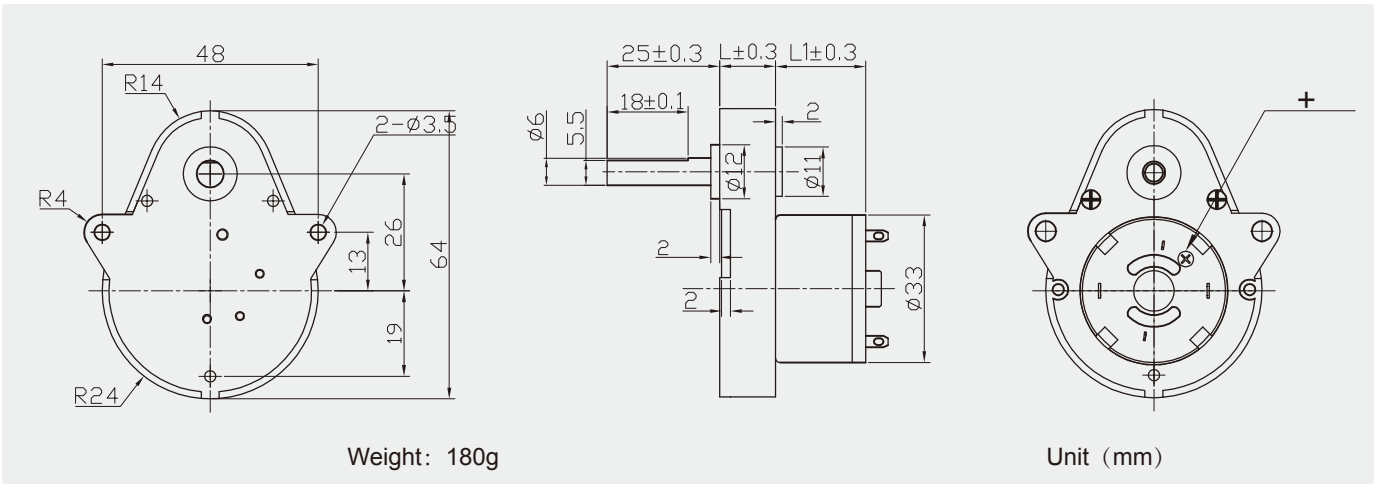

Voltage, rated torque, speed, current, power and shaft size can be customized as requirement.

Technical Data

MODEL	VOLTAGE	NO-LOAD		AT MAXIMUM EFFICIENCY			STALL TORQUE			GEAR RATIO	LENGTH OF GEAR BOX (L)	MATCH THE MOTOR	LENGTH OF MOTOR (L1)	
		SPEED	CURRENT	SPEED	CURRENT	TORQUE	TORQUE	CURRENT						
	V	r/min	A	r/min	A	mN.m	Kg.cm	mN.m	Kg.cm	A	mm	mm		
JL-48E528-30	24	274	0.050	230	0.26	129.5	1.32	388.5	3.96	1.32	30	12.4	JRF/K-528	30
JL-48E528-56	24	147	0.050	123	0.26	241.8	2.47	725.4	7.40	1.32	56	12.4	JRF/K-528	30
JL-48E528-75	24	109	0.056	92	0.29	323.9	3.30	906.9	9.25	1.32	75	12.4	JRF/K-528	30
JL-48E528-112	24	73	0.056	62	0.29	483.6	4.93	1160.6	11.84	1.32	112	12.4	JRF/K-528	30
JL-48E528-160	24	51	0.056	43	0.29	690.9	7.04	1589.1	16.20	1.32	160	12.4	JRF/K-528	30
JL-48E528-216	24	38	0.056	32	0.29	750.8	7.66	1750.4	17.85	1.32	216	12.4	JRF/K-528	30
JL-48E528-427	24	19	0.063	16	0.33	860.2	8.77	1885.2	19.22	1.32	427	12.4	JRF/K-528	30
JL-48E528-538	24	15	0.063	13	0.33	1050.3	10.71	2150.8	21.93	1.32	538	12.4	JRF/K-528	30

Packing Details

QTY: 100pcs/ctn Carton Size: 33.5*32.8*26.8 cm Gross Weight: .18.5 kg/ctn Net Weight: 18 kg/ctn



Typical Applications

- Household Appliances: Electric curtain, Intergrated cooker, Coffee maker, Intelligent closetool, Sweeping robot, Dish-washing Machine, Cooker hood, Electric lock.
- Hair Care: Hair Curler, Massager, Electric Hair Clipper
- Office Equipment: Shredder, Printer, Projector, Counting Machine
- Medical Equipment: Massage chair, Electric trolley, Medical pump, Electric bed, Electric wheelchair
- Industrial Equipment: Water, electrical and gas valve, Air switch, Pump, Automatic door, Automatic lubrication equipment.
- Business Equipment: Vending machines, Parking locks, ATM machines, Stage lights.
- Intelligent Robot: Mechanical Arm, UAV (Unmanned Aerial Vehicle), Service Robot

Outline Dimension

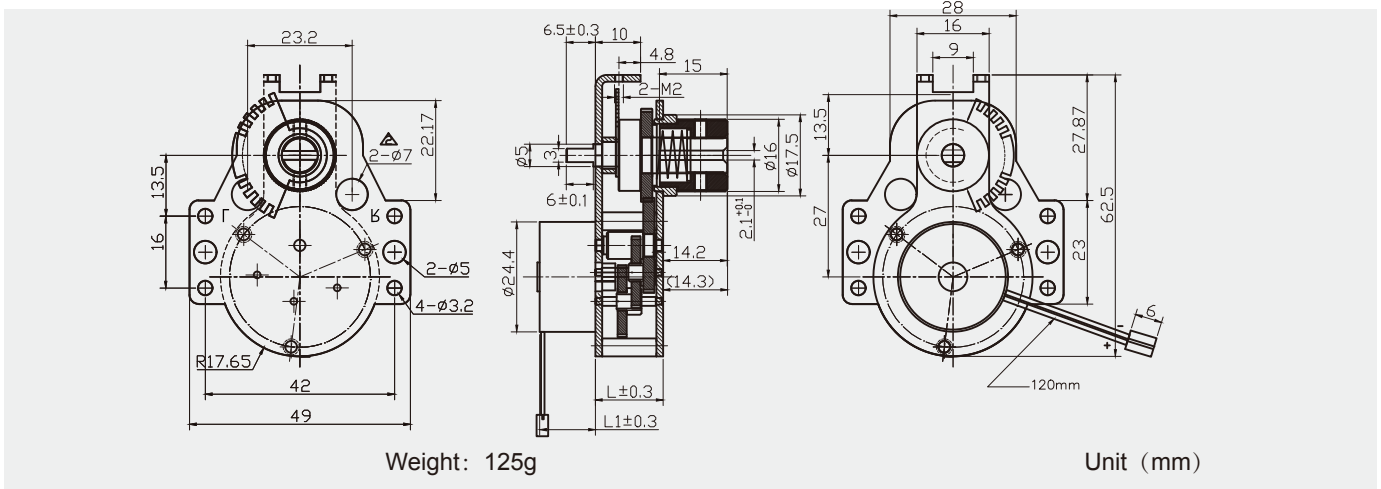

Voltage, rated torque, speed, current, power and shaft size can be customized as requirement.

Technical Data

MODEL	VOLTAGE	NO-LOAD		AT MAXIMUM EFFICIENCY			STALL TORQUE			GEAR RATIO	LENGTH OF GEAR BOX (L)	MATCH THE MOTOR	LENGTH OF MOTOR (L1)	
		SPEED	CURRENT	SPEED	CURRENT	TORQUE	TORQUE	CURRENT						
		r/min	A	r/min	A	mN.m	Kg.cm	mN.m	Kg.cm					A
JL-49F300-148	5	58	0.05	50	0.2	60.8	0.62	440.0	4.49	1.13	148	15	JRF/K-300	12.3

Packing Details

QTY: 80 pcs/ctn Carton Size: 40.5*28*25 cm Gross Weight: .10.5 kg/ctn Net Weight: 10 kg/ctn



Typical Applications

- Household Appliances: Electric curtain, Intergrated cooker, Coffee maker, Intelligent closetool, Sweeping robot, Dish-washing Machine, Cooker hood, Electric lock.
- Hair Care: Hair Curler, Massager, Electric Hair Clipper
- Office Equipment: Shredder, Printer, Projector, Counting Machine
- Medical Equipment: Massage chair, Electric trolley, Medical pump, Electric bed, Electric wheelchair
- Industrial Equipment: Water, electrical and gas valve, Air switch, Pump, Automatic door, Automatic lubrication equipment.
- Business Equipment: Vending machines, Parking locks, ATM machines, Stage lights.
- Intelligent Robot: Mechanical Arm, UAV (Unmanned Aerial Vehicle), Service Robot

Outline Dimension

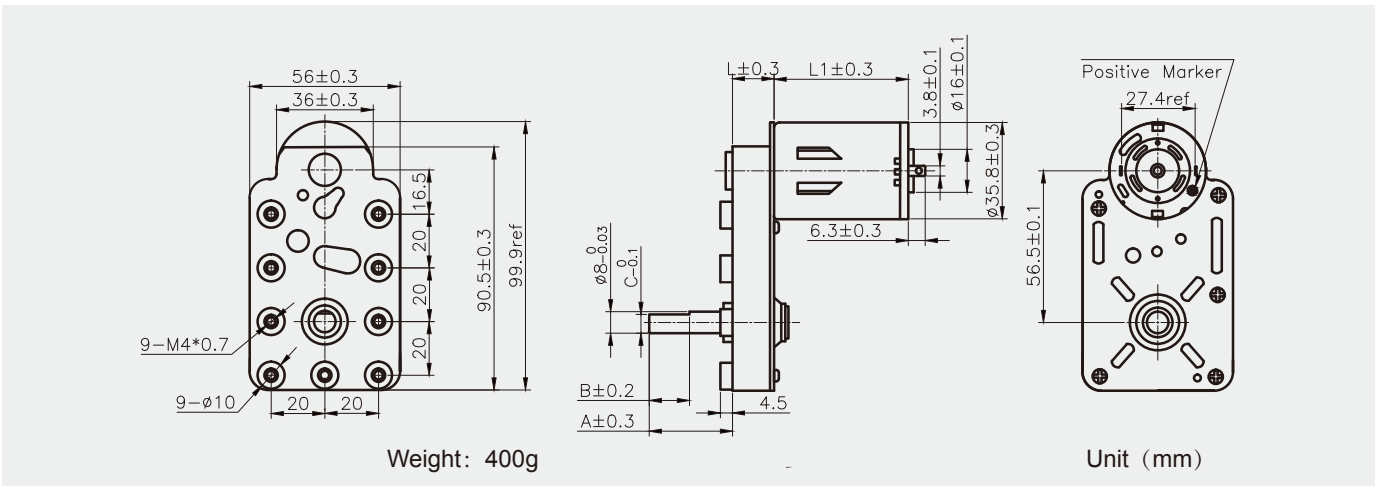

Voltage, rated torque, speed, current, power and shaft size can be customized as requirement.

Technical Data

MODEL	VOLTAGE	NO-LOAD		AT MAXIMUM EFFICIENCY			STALL TORQUE			GEAR RATIO	LENGTH OF GEAR BOX(L)	MATCH THE MOTOR	LENGTH OF MOTOR(L1)
		SPEED	CURRENT	SPEED	CURRENT	TORQUE	TORQUE	CURRENT					
	V	r/min	A	r/min	A	mN.m	Kg.cm	mN.m	Kg.cm	A	mm		mm
JL-56F545-38	24	132	0.24	102	0.82	902.0	9.20	2706.0	27.59	2.80	38	JRK-545	50
JL-56F545-42	24	119	0.24	92	0.82	996.9	10.17	2990.7	30.50	2.80	42	JRK-545	50
JL-56F545-85	24	59	0.27	45	0.91	1506.8	15.36	4520.4	46.09	2.80	85	JRK-545	50
JL-56F545-200	24	25	0.30	19	1.03	2830.5	28.86	7076.3	72.16	2.80	200	JRK-545	50
JL-56F545-403	24	12	0.34	10	1.17	3685.3	37.58	9213.3	93.95	2.80	403	JRK-545	50
JL-56F545-453	24	11	0.34	9	1.17	4205.8	42.89	10514.5	107.22	2.80	453	JRK-545	50

Packing Details

QTY: 32 pcs/ctn Carton Size: 36.5*26.5*24 cm Gross Weight: 15 kg/ctn Net Weight: 14 kg/ctn

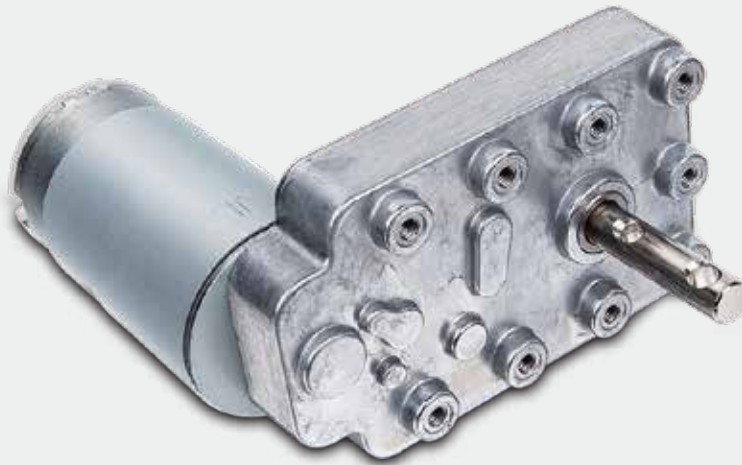

Typical Applications

- Household Appliances: Electric curtain, Intergrated cooker, Coffee maker, Intelligent closetool, Sweeping robot, Dish-washing Machine, Cooker hood, Electric lock.
- Hair Care: Hair Curler, Massager, Electric Hair Clipper
- Office Equipment: Shredder, Printer, Projector, Counting Machine
- Medical Equipment: Massage chair, Electric trolley, Medical pump, Electric bed, Electric wheelchair
- Industrial Equipment: Water, electrical and gas valve, Air switch, Pump, Automatic door, Automatic lubrication equipment.
- Business Equipment: Vending machines, Parking locks, ATM machines, Stage lights.
- Intelligent Robot: Mechanical Arm, UAV (Unmanned Aerial Vehicle), Service Robot

Outline Dimension

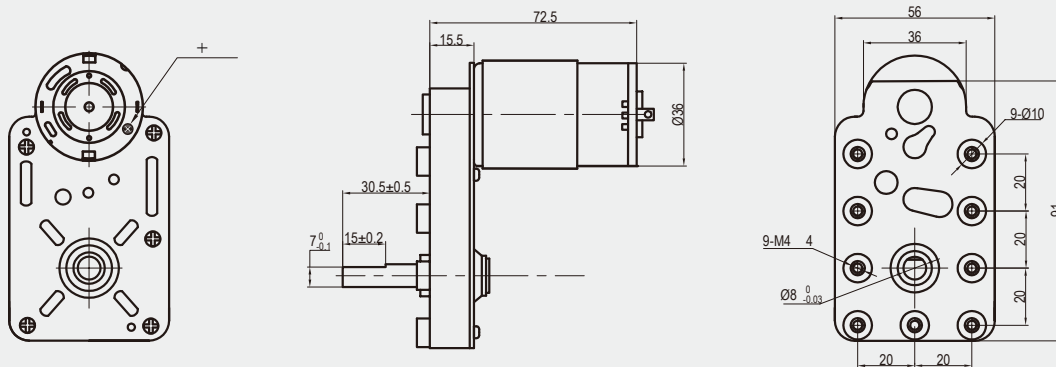

Weight: 360g

Unit (mm)

Voltage, rated torque, speed, current, power and shaft size can be customized as requirement.

Technical Data

MODEL	VOLTAGE V	NO-LOAD		AT MAXIMUM EFFICIENCY			STALL TORQUE			GEAR RATIO	LENGTH OF GEAR BOX(L) mm	MATCH THE MOTOR	LENGTH OF MOTOR(L1) mm
		SPEED r/min	CURRENT A	SPEED r/min	CURRENT A	TORQUE mN.m	TORQUE Kg.cm	TORQUE mN.m	TORQUE Kg.cm				
JL-56F555-38	12	221	0.72	180	3.12	1146.3	11.69	3482.5	35.07	13.52	38	JRK-555	57
JL-56F555-42	12	200	0.72	163	3.12	1267.0	12.92	4434.5	45.30	13.52	42	JRK-555	57
JL-56F555-85	12	99	0.8	81	3.47	2564.1	26.15	7692.3	78.44	13.52	85	JRK-555	57
JL-56F555-200	12	42	0.90	34	3.90	3580.3	36.51	10740.9	109.52	13.52	200	JRK-555	57
JL-56F555-403	12	21	1.03	17	4.46	4275.6	43.60	12826.8	130.79	13.52	403	JRK-555	57
JL-56F555-453	12	19	1.03	15	4.46	4532.5	46.33	14504.0	147.90	13.52	453	JRK-555	57

Packing Details

QTY: 32 pcs/ctn Carton Size: 36.5*26.5*24 cm Gross Weight: 12 kg/ctn Net Weight: 11.5 kg/ctn



Typical Applications

- Household Appliances: Electric curtain, Intergrated cooker, Coffee maker, Intelligent closetool, Sweeping robot, Dish-washing Machine, Cooker hood, Electric lock.
- Hair Care: Hair Curler, Massager, Electric Hair Clipper
- Office Equipment: Shredder, Printer, Projector, Counting Machine
- Medical Equipment: Massage chair, Electric trolley, Medical pump, Electric bed, Electric wheelchair
- Industrial Equipment: Water, electrical and gas valve, Air switch, Pump, Automatic door, Automatic lubrication equipment.
- Business Equipment: Vending machines, Parking locks, ATM machines, Stage lights.
- Intelligent Robot: Mechanical Arm, UAV (Unmanned Aerial Vehicle), Service Robot

Outline Dimension

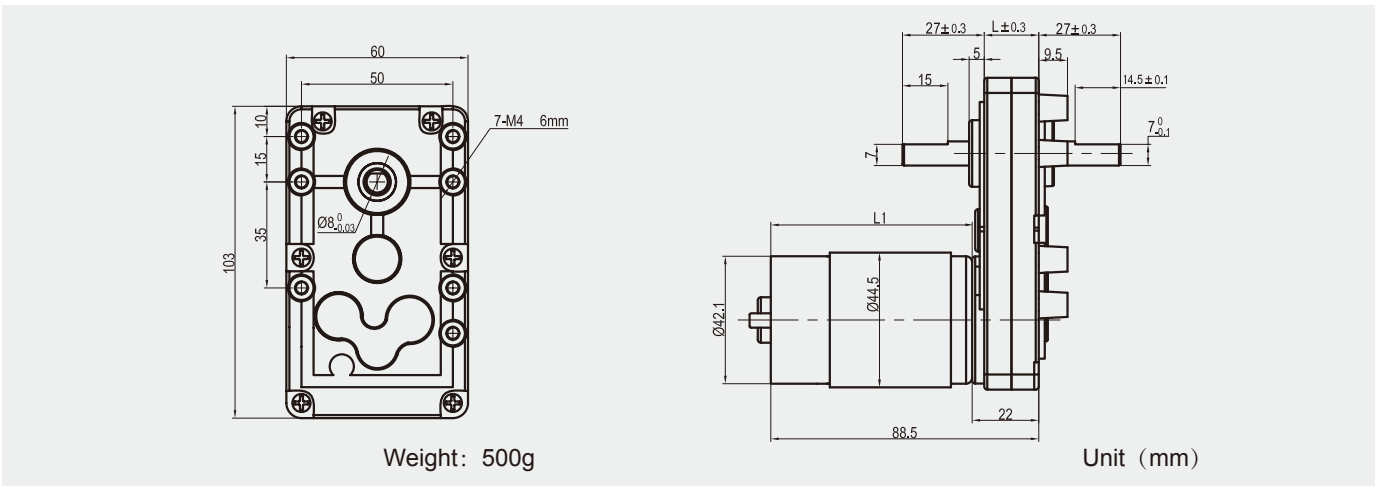

Voltage, rated torque, speed, current, power and shaft size can be customized as requirement.

Technical Data

MODEL	VOLTAGE V	NO-LOAD		AT MAXIMUM EFFICIENCY				STALL TORQUE			GEAR RATIO	LENGTH OF GEAR BOX (L)	MATCH THE MOTOR	LENGTH OF MOTOR (L1)
		SPEED	CURRENT	SPEED	CURRENT	TORQUE		TORQUE	CURRENT					
		r/min	A	r/min	A	mN.m	Kg.cm	mN.m	Kg.cm	A				
JL-60A775-59	24	65	0.35	52	1.36	2536.6	25.87	7609.8	77.60	5.25	59	18	RS-775	66.5
JL-60A775-73	24	53	0.35	42	1.36	3138.5	32.00	9415.5	96.01	5.25	73	18	RS-775	66.5
JL-60A775-132	24	29	0.39	23	1.51	4050.2	41.30	12380.6	126.24	5.25	132	18	RS-775	66.5

Packing Details

QTY: 32 pcs/ctn Carton Size: 36.5*26.5*24 cm Gross Weight: 22 kg/ctn Net Weight: 21 kg/ctn



Typical Applications

- Household Appliances: Electric curtain, Intergrated cooker, Coffee maker, Intelligent closetool, Sweeping robot, Dish-washing Machine, Cooker hood, Electric lock.
- Hair Care: Hair Curler, Massager, Electric Hair Clipper
- Office Equipment: Shredder, Printer, Projector, Counting Machine
- Medical Equipment: Massage chair, Electric trolley, Medical pump, Electric bed, Electric wheelchair
- Industrial Equipment: Water, electrical and gas valve, Air switch, Pump, Automatic door, Automatic lubrication equipment.
- Business Equipment: Vending machines, Parking locks, ATM machines, Stage lights.
- Intelligent Robot: Mechanical Arm, UAV (Unmanned Aerial Vehicle), Service Robot

Outline Dimension

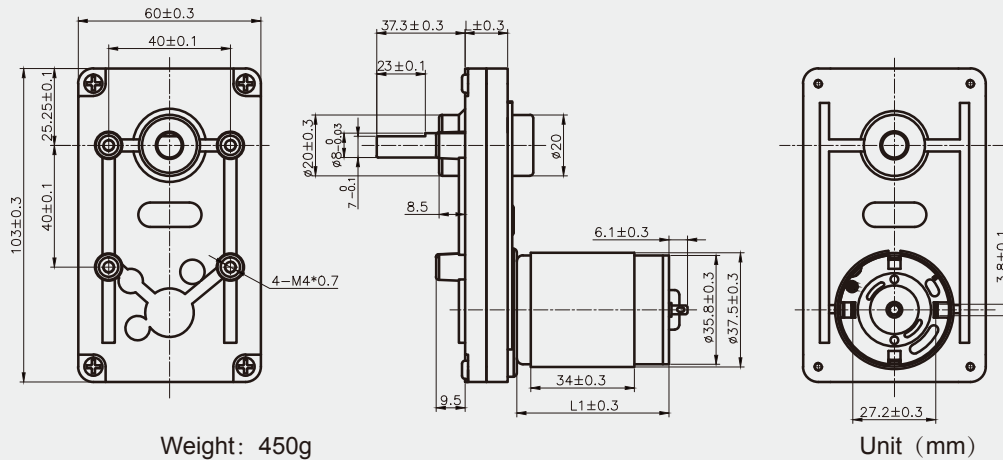

Voltage, rated torque, speed, current, power and shaft size can be customized as requirement.

Technical Data

MODEL	VOLTAGE	NO-LOAD		AT MAXIMUM EFFICIENCY			STALL TORQUE			GEAR RATIO	LENGTH OF GEAR BOX (L)	MATCH THE MOTOR	LENGTH OF MOTOR (L1)	
		SPEED	CURRENT	SPEED	CURRENT	TORQUE	TORQUE	CURRENT						
	V	r/min	A	r/min	A	mN.m	Kg.cm	mN.m	Kg.cm	A	mm		mm	
JL-60B555-73	24	90	0.38	70	1.79	2530	25.8	18.5	9035.2	92.13	6.73	73	14	JRK-555

Packing Details

QTY: 32 pcs/ctn Carton Size: 36.5*26.5*25 cm Gross Weight: 15 kg/ctn Net Weight: 14 kg/ctn

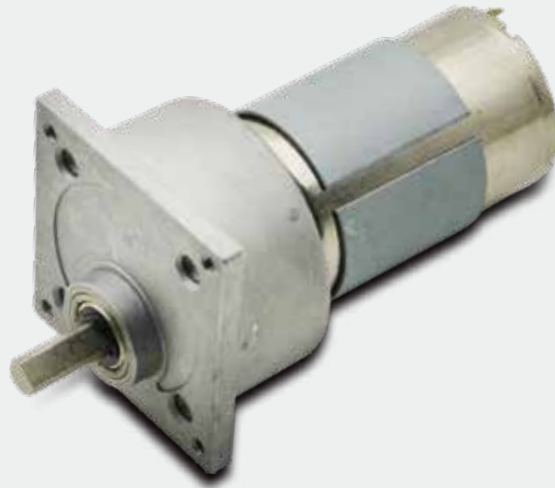

Typical Applications

- Household Appliances: Electric curtain, Intergrated cooker, Coffee maker, Intelligent closetool, Sweeping robot, Dish-washing Machine, Cooker hood, Electric lock.
- Hair Care: Hair Curler, Massager, Electric Hair Clipper
- Office Equipment: Shredder, Printer, Projector, Counting Machine
- Medical Equipment: Massage chair, Electric trolley, Medical pump, Electric bed, Electric wheelchair
- Industrial Equipment: Water, electrical and gas valve, Air switch, Pump, Automatic door, Automatic lubrication equipment.
- Business Equipment: Vending machines, Parking locks, ATM machines, Stage lights.
- Intelligent Robot: Mechanical Arm, UAV (Unmanned Aerial Vehicle), Service Robot

Outline Dimension

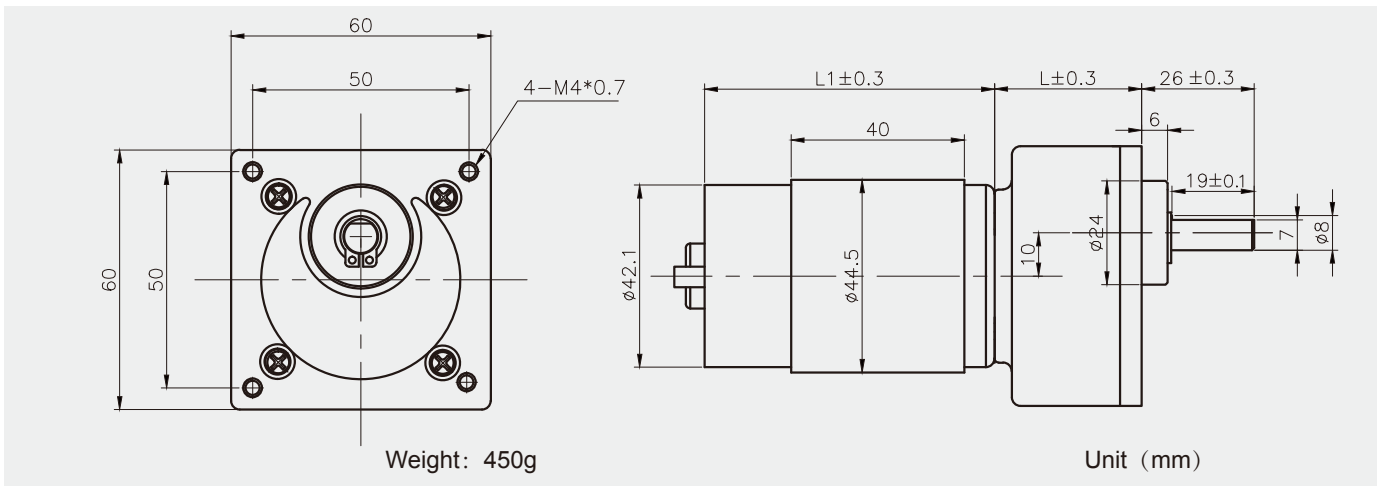

Voltage, rated torque, speed, current, power and shaft size can be customized as requirement.

Technical Data

MODEL	VOLTAGE V	NO-LOAD		AT MAXIMUM EFFICIENCY				STALL TORQUE			GEAR RATIO	LENGTH OF GEAR BOX (L) mm	MATCH THE MOTOR	LENGTH OF MOTOR (L1) mm
		SPEED r/min	CURRENT A	SPEED r/min	CURRENT A	TORQUE		TORQUE	CURRENT					
						mN.m	Kg.cm	mN.m	Kg.cm	A				
JL-60R528-28	24	72	0.015	64.7	0.03	44.8	0.46	44.8	0.46	0.16	28	34	JRF/K-528	30
JL-60R528-92	24	22	0.015	19.7	0.03	147.1	1.50	147.1	10.00	0.16	92	34	JRF/K-528	30
JL-60R555-28	12	88	0.177	69	0.49	342.3	3.49	1237.5	12.62	1.90	28	34	JRK-555	57
JL-60R555-92	12	27	0.177	21	0.49	1124.7	11.47	4066.1	41.46	1.90	92	34	JRK-555	57
JL-60R775-28	12	66	0.15	53	0.58	673.2	6.86	3367.2	34.34	2.40	28	34	JRS-775	66.5
JL-60R775-92	12	20	0.15	16	0.58	2211.8	22.55	11063.8	112.82	2.40	92	34	JRS-775	66.5

Packing Details

QTY: 32 pcs/ctn Carton Size: 36.5*26.5*25 cm Gross Weight: 18 kg/ctn Net Weight: 17 kg/ctn



Typical Applications

- Household Appliances: Electric curtain, Intergrated cooker, Coffee maker, Intelligent closetool, Sweeping robot, Dish-washing Machine, Cooker hood, Electric lock.
- Hair Care: Hair Curler, Massager, Electric Hair Clipper
- Office Equipment: Shredder, Printer, Projector, Counting Machine
- Medical Equipment: Massage chair, Electric trolley, Medical pump, Electric bed, Electric wheelchair
- Industrial Equipment: Water, electrical and gas valve, Air switch, Pump, Automatic door, Automatic lubrication equipment.
- Business Equipment: Vending machines, Parking locks, ATM machines, Stage lights.
- Intelligent Robot: Mechanical Arm, UAV(Unmanned Aerial Vehicle), Service Robot

Outline Dimension

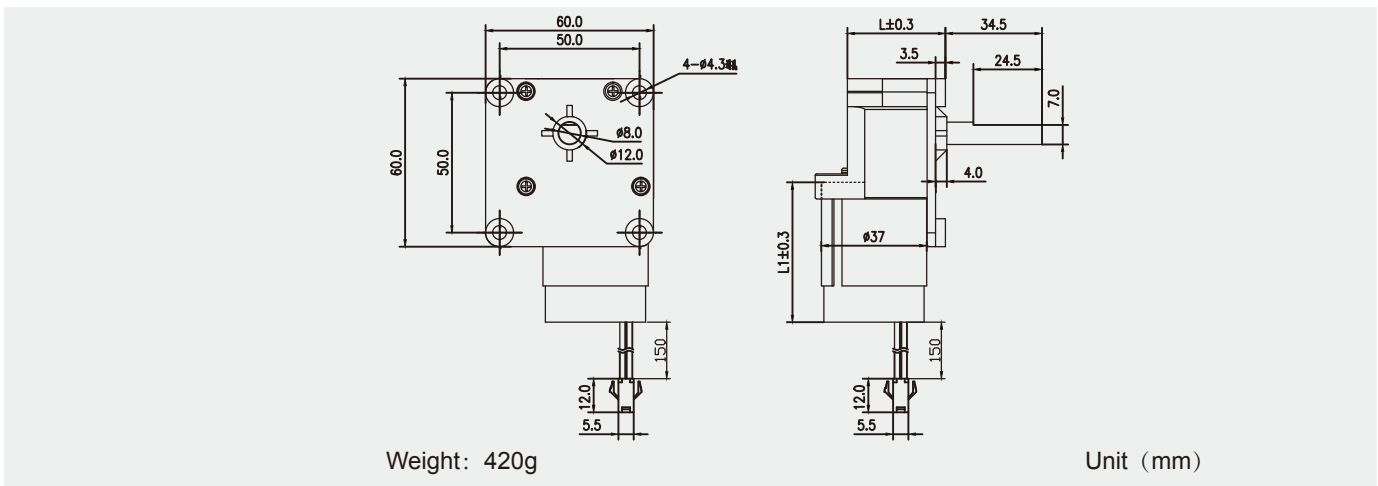

Voltage, rated torque, speed, current, power and shaft size can be customized as requirement.

Technical Data

MODEL	VOLTAGE	NO-LOAD		AT MAXIMUM EFFICIENCY				STALL TORQUE			GEAR RATIO	LENGTH OF GEAR BOX(L)	MATCH THE MOTOR	LENGTH OF MOTOR(L1)
		SPEED	CURRENT	SPEED	CURRENT	TORQUE		TORQUE	CURRENT					
		r/min	A	r/min	A	mN.m	Kg.cm	mN.m	Kg.cm	A				
JL-60Z545-28	24	95	0.065	79	0.18	117	1.2	1.3	823	8	0.79	28	JRS-545	50
JL-60Z545-56	24	48	0.067	40	0.23	235	2.4	0.9	1078	11	0.8	56	JRS-545	50

Packing Details

QTY: 32 pcs/ctn Carton Size: 36.5*26.5*24 cm Gross Weight: 15 kg/ctn Net Weight: 14 kg/ctn



Typical Applications

- Household Appliances: Electric curtain, Intergrated cooker, Coffee maker, Intelligent closetool, Sweeping robot, Dish-washing Machine, Cooker hood, Electric lock.
- Hair Care: Hair Curler, Massager, Electric Hair Clipper
- Office Equipment: Shredder, Printer, Projector, Counting Machine
- Medical Equipment: Massage chair, Electric trolley, Medical pump, Electric bed, Electric wheelchair
- Industrial Equipment: Water, electrical and gas valve, Air switch, Pump, Automatic door, Automatic lubrication equipment.
- Business Equipment: Vending machines, Parking locks, ATM machines, Stage lights.
- Intelligent Robot: Mechanical Arm, UAV(Unmanned Aerial Vehicle), Service Robot

Outline Dimension

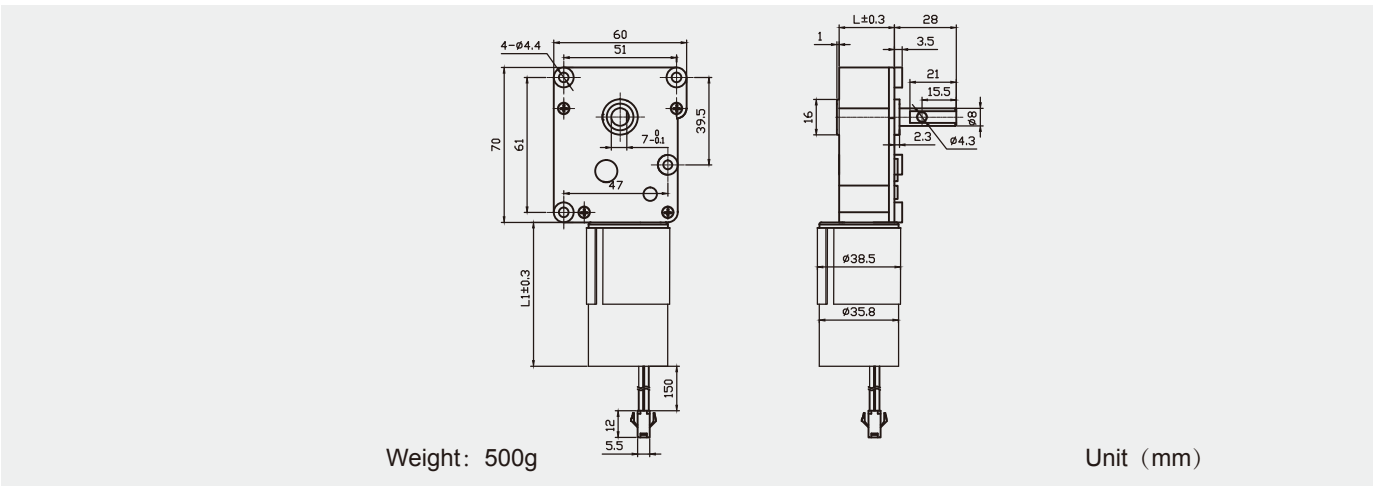

Voltage, rated torque, speed, current, power and shaft size can be customized as requirement.

Technical Data

MODEL	VOLTAGE	NO- LOAD		AT MAXIMUM EFFICIENCY				STALL TORQUE			GEAR RATIO	LENGTH OF GEAR BOX(L)	MATCH THE MOTOR	LENGTH OF MOTOR(L1)
		SPEED	CURRENT	SPEED	CURRENT	TORQUE		TORQUE		CURRENT				
		r/min	A	r/min	A	mN.m	Kg.cm	mN.m	Kg.cm	A				
JL-70Z575-97	24	32	0.08	26	0.53	1765	18	8333	85	2.19	97	70	JRS-575	67.5

Packing Details

QTY: 32 pcs/ctn Carton Size: 36.5*26.5*24 cm Gross Weight: 17 kg/ctn Net Weight: 16 kg/ctn



典型应用

- 家用电器：电动窗帘，集成灶，咖啡机，智能马桶，扫地机器人，洗碗机，油烟机，智能门锁
- 个人护理：卷发器，按摩仪器，电动理发器
- 办公设备：碎纸机，打印机，投影仪，数钞机，数币机
- 医疗设备：按摩椅，电动推车，医疗泵，电动床，电动轮椅
- 工业设备：水电气阀门，空气开关，泵，自动门开关，自动润滑设备
- 商业设备：自动售卖机，车位锁，ATM机，智能灯具
- 机器人：机械手，无人机，服务机器人

外形尺寸

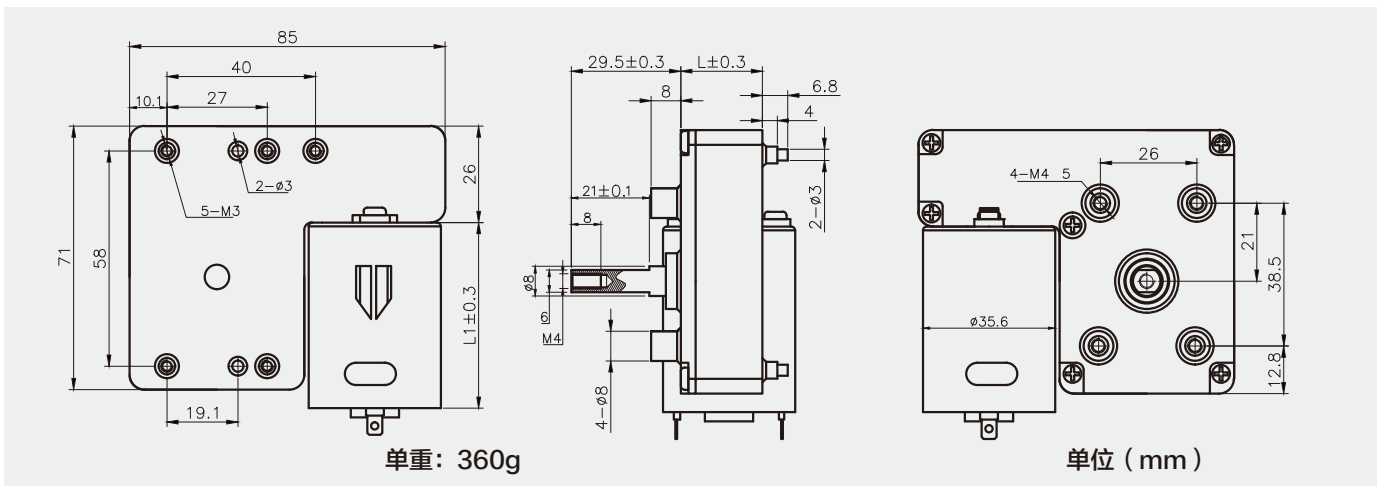

电压，扭矩，转速，电流，功率，输出轴的尺寸可以按照客户需求定制。

技术数据

规格	电压	空载		负载			堵转		齿轮 减速比	齿轮箱 长度(L)	匹配电机	电机长度(L1)		
		转速	电流	转速	电流	转矩	转矩	电流						
	V	r/min	A	r/min	A	mN.m	Kg.cm	mN.m	Kg.cm	A	mm	mm		
JL-85Z545-50	24	177.3	0.249	146.0	1.16	459.5	4.69	2801.8	28.57	5.40	50	22	JRK-545	50
JL-85Z545-50.6	24	175.2	0.249	144.3	1.16	465.0	4.74	2835.4	28.91	5.40	50.6	22	JRK-545	50

装箱信息

数量: 32pcs/ctn 纸箱尺寸: 40.5*28*25 cm 毛重: 12 kg/ctn 净重: 11 kg/ctn



Typical Applications

- Smart Locks: Door Lock, Fingerprint Lock, Express Cabinet Lock, Bike Lock
- Household Appliances: Hair Curler
- Financial Medical Equipment: 3Doodler
- Industrial Equipment: Air Switch
- Intelligent Robot: Mechanical Arm, UAV(Unmanned Aerial Vehicle), Service Robot

Outline Dimension

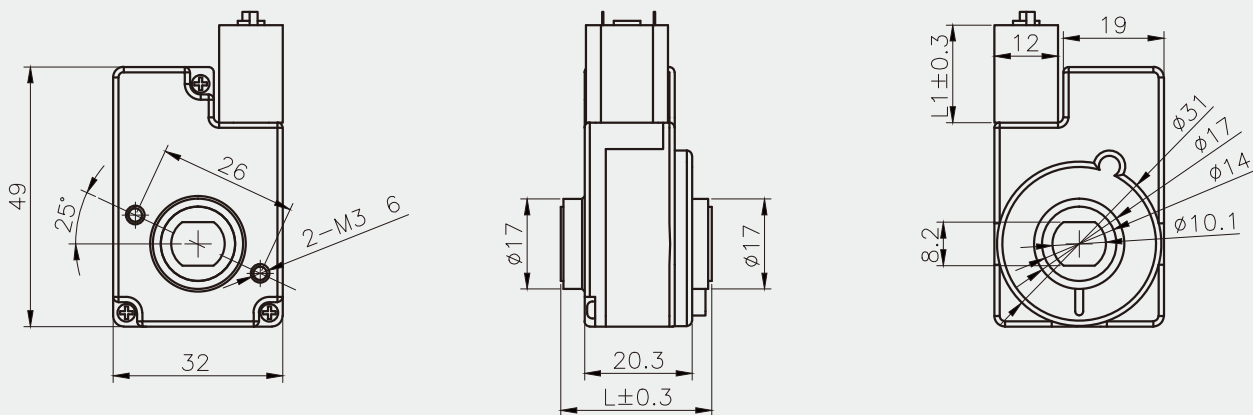

Weight: 10g

Unit (mm)

Voltage, rated torque, speed, current, power and shaft size can be customized as requirement.

Technical Data

MODEL	VOLTAGE	NO-LOAD		AT MAXIMUM EFFICIENCY				STALL TORQUE			GEAR RATIO	LENGTH OF GEAR BOX(L)	MATCH THE MOTOR	LENGTH OF MOTOR(L1)
		SPEED	CURRENT	SPEED	CURRENT	TORQUE		TORQUE	CURRENT					
		V	r/min	A	r/min	A	mN.m	Kg.cm	mN.m	Kg.cm				
JL-3249F030-3993	7	4	0.11	3.04	0.17	588.2	6	0.24				mm	49	30

Packing Details

QTY: 1000 pcs/ctn Carton Size: 36.5*26.5*25 cm Gross Weight: 10.5 kg/ctn Net Weight: 10 kg/ctn



Typical Applications

- Household Appliances: Electric curtain, Intergrated cooker, Coffee maker, Intelligent closetool, Sweeping robot, Dish-washing Machine, Cooker hood, Electric lock.
- Hair Care: Hair Curler, Massager, Electric Hair Clipper
- Office Equipment: Shredder, Printer, Projector, Counting Machine
- Medical Equipment: Massage chair, Electric trolley, Medical pump, Electric bed, Electric wheelchair
- Industrial Equipment: Water, electrical and gas valve, Air switch, Pump, Automatic door, Automatic lubrication equipment.
- Business Equipment: Vending machines, Parking locks, ATM machines, Stage lights.
- Intelligent Robot: Mechanical Arm, UAV (Unmanned Aerial Vehicle), Service Robot

Outline Dimension

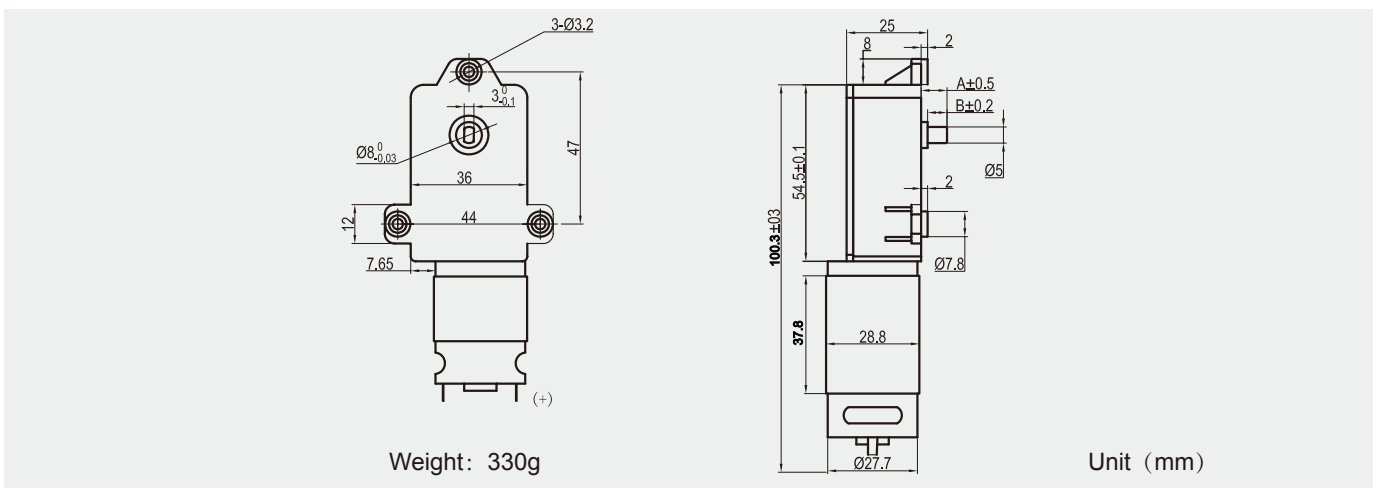

Voltage, rated torque, speed, current, power and shaft size can be customized as requirement.

Technical Data

MODEL	VOLTAGE	NO- LOAD		AT MAXIMUM EFFICIENCY				STALL TORQUE			GEAR RATIO	LENGTH OF GEAR BOX(L)	MATCH THE MOTOR	LENGTH OF MOTOR(L1)
		SPEED	CURRENT	SPEED	CURRENT	TORQUE		TORQUE	CURRENT					
		r/min	A	r/min	A	mN.m	Kg.cm	mN.m	Kg.cm	A				
JL-3655Z385-113	8	76.3	0.23	62.0	1.02	482.8	4.92	2578.4	26.29	4.45	113	25	JRK-38	37.8
JL-3655Z385-1074	8	8.0	0.23	6.5	1.02	3580.2	36.51	10740.6	109.52	4.45	1074	25	JRK-385	37.8
JL-3655Z385-1582	8	5.5	0.23	4.4	1.02	4235.8	43.19	12707.4	129.58	4.45	1582	25	JRK-385	37.8

Packing Details

QTY: 40pcs/ctn Carton Size: 85*39.5*29.5 cm Gross Weight: 14 kg/ctn Net Weight: 13 kg/ctn



Typical Applications

- Household Appliances: Electric curtain, Intergrated cooker, Coffee maker, Intelligent closetool, Sweeping robot, Dish-washing Machine, Cooker hood, Electric lock.
- Hair Care: Hair Curler, Massager, Electric Hair Clipper
- Office Equipment: Shredder, Printer, Projector, Counting Machine
- Medical Equipment: Massage chair, Electric trolley, Medical pump, Electric bed, Electric wheelchair
- Industrial Equipment: Water, electrical and gas valve, Air switch, Pump, Automatic door, Automatic lubrication equipment.
- Business Equipment: Vending machines, Parking locks, ATM machines, Stage lights.
- Intelligent Robot: Mechanical Arm, UAV (Unmanned Aerial Vehicle), Service Robot

Outline Dimension

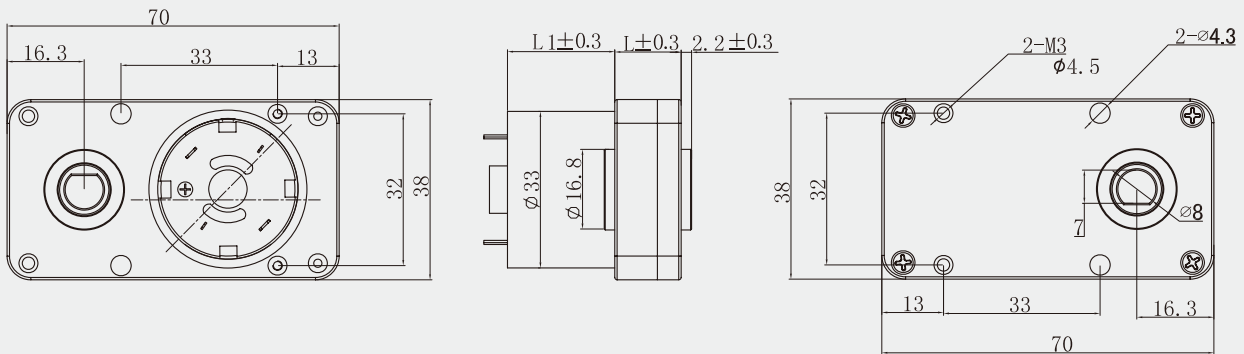

Weight: 200g

Unit (mm)

Voltage, rated torque, speed, current, power and shaft size can be customized as requirement.

Technical Data

MODEL	VOLTAGE	NO-LOAD		AT MAXIMUM EFFICIENCY				STALL TORQUE			GEAR RATIO	LENGTH OF GEAR BOX (L)	MATCH THE MOTOR	LENGTH OF MOTOR (L1)
		SPEED	CURRENT	SPEED	CURRENT	TORQUE		TORQUE	CURRENT					
	V	r/min	A	r/min	A	mN.m	Kg.cm	mN.m	Kg.cm	A				
JL-3870F520-4	4	1952.5	0.3	1476.8	0.92	8.3	0.08	27.6	0.28	3.4	4	14	JRF/K-520	22.6
JL-3870F520-142	4	55	0.3	41.6	0.92	294.0	3.00	980.0	10.00	3.4	142	14	JRF/K-520	22.6

Packing Details

QTY: 120pcs/ctn Carton Size: 40.5*28*25 cm Gross Weight: .22 kg/ctn Net Weight: 21 kg/ctn



Typical Applications

- Household Appliances: Electric curtain, Intergrated cooker, Coffee maker, Intelligent closetool, Sweeping robot, Dish-washing Machine, Cooker hood, Electric lock.
- Hair Care: Hair Curler, Massager, Electric Hair Clipper
- Office Equipment: Shredder, Printer, Projector, Counting Machine
- Medical Equipment: Massage chair, Electric trolley, Medical pump, Electric bed, Electric wheelchair
- Industrial Equipment: Water, electrical and gas valve, Air switch, Pump, Automatic door, Automatic lubrication equipment.
- Business Equipment: Vending machines, Parking locks, ATM machines, Stage lights.

Outline Dimension

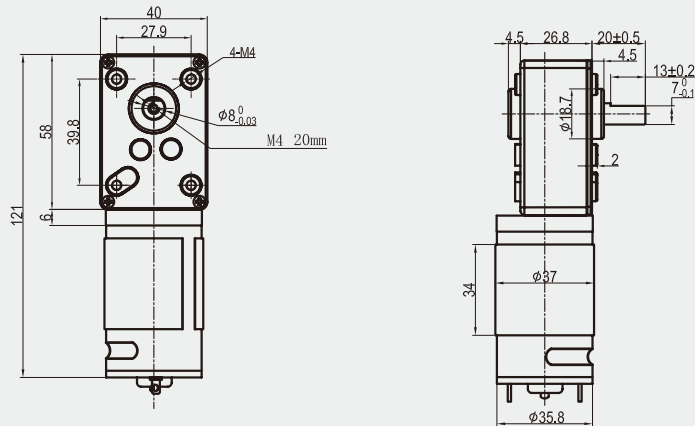

Weight: 10g

Unit (mm)

Voltage, rated torque, speed, current, power and shaft size can be customized as requirement.

Technical Data

MODEL	VOLTAGE	NO- LOAD		AT MAXIMUM EFFICIENCY				STALL TORQUE			GEAR RATIO	LENGTH OF GEAR BOX(L)	MATCH THE MOTOR	LENGTH OF MOTOR(L1)
		SPEED	CURRENT	SPEED	CURRENT	TORQUE		TORQUE	CURRENT					
		r/min	A	r/min	A	mN.m	Kg.cm	mN.m	Kg.cm	A				
V	r/min	A	r/min	A	mN.m	Kg.cm	mN.m	Kg.cm	A	mm		mm		
JL-4058Z555-343.6	12	22	0.34	18.7	1.70	2400	24.45	8400.0	84.20	5.00	343.6	58.2	JRK-555	57
JL-4058Z555-455.5	24	11	0.45	10.0	2.00	3000	30.45	10530.2	105.40	5.00	455.5	58.2	JRK-555	57

Packing Details

QTY: 1000 pcs/ctn Carton Size: 36.5*26.5*25 cm Gross Weight: 10.5 kg/ctn Net Weight: 10 kg/ctn

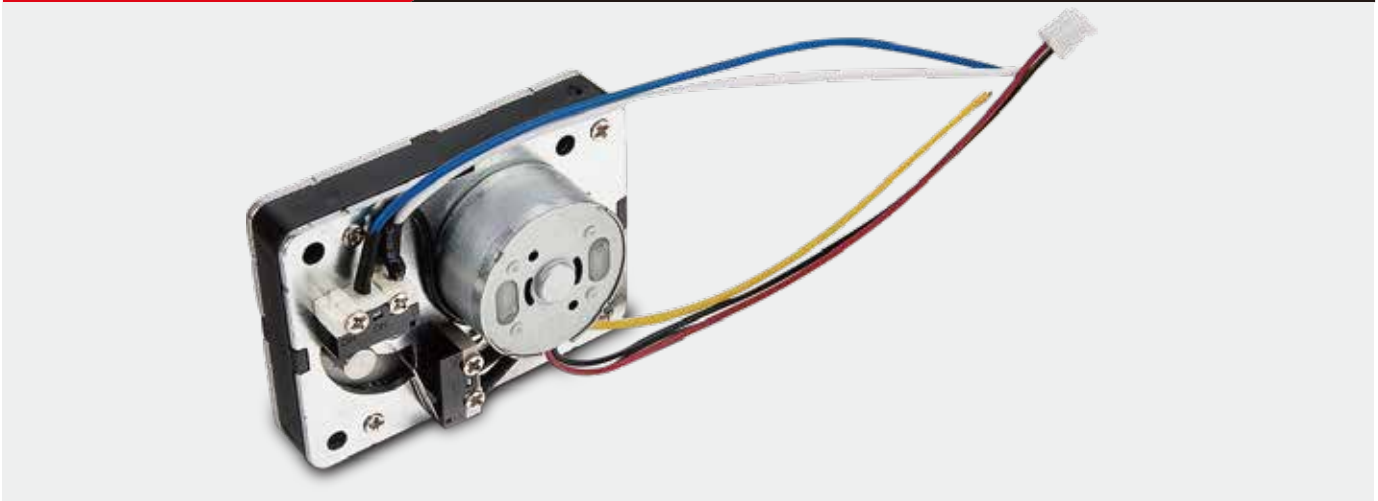

Typical Applications

- Household Appliances: Electric curtain, Intergrated cooker, Coffee maker, Intelligent closetool, Sweeping robot, Dish-washing Machine, Cooker hood, Electric lock.
- Hair Care: Hair Curler, Massager, Electric Hair Clipper
- Office Equipment: Shredder, Printer, Projector, Counting Machine
- Medical Equipment: Massage chair, Electric trolley, Medical pump, Electric bed, Electric wheelchair
- Industrial Equipment: Water, electrical and gas valve, Air switch, Pump, Automatic door, Automatic lubrication equipment.
- Business Equipment: Vending machines, Parking locks, ATM machines, Stage lights.
- Intelligent Robot: Mechanical Arm, UAV (Unmanned Aerial Vehicle), Service Robot

Outline Dimension

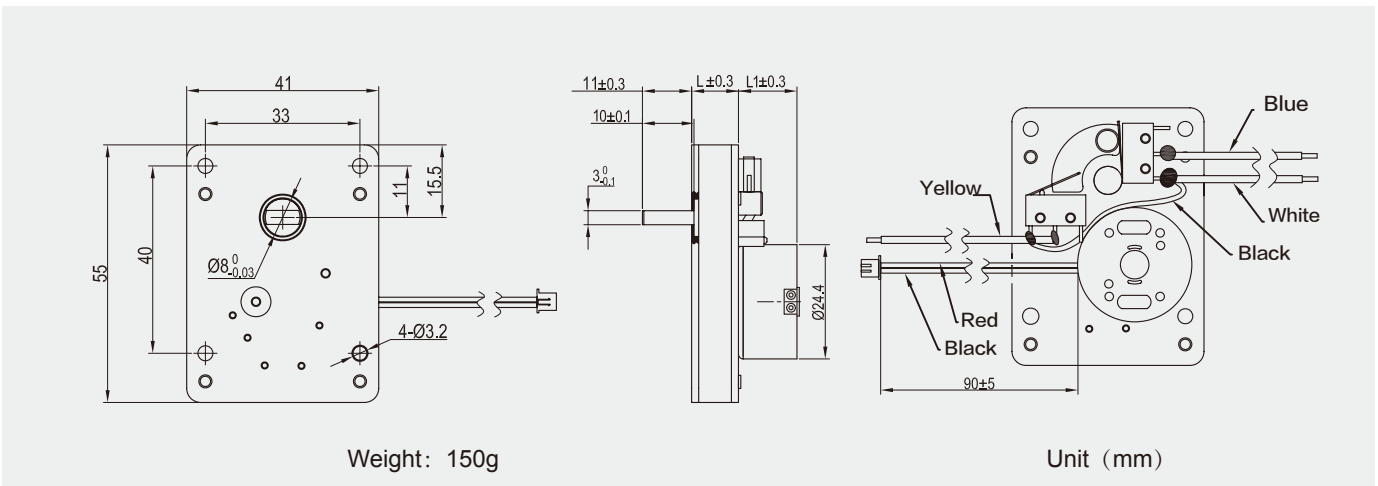

Voltage, rated torque, speed, current, power and shaft size can be customized as requirement.

Technical Data

MODEL	VOLTAGE	NO-LOAD		AT MAXIMUM EFFICIENCY				STALL TORQUE			GEAR RATIO	LENGTH OF GEAR BOX (L)	MATCH THE MOTOR	LENGTH OF MOTOR (L1)
		SPEED	CURRENT	SPEED	CURRENT	TORQUE		TORQUE	CURRENT					
		V	r/min	A	r/min	A	mN.m	Kg.cm	mN.m	Kg.cm				
JL-5541F300-5696	3	0.6	0.02	0.5	0.08	1176.0	12.00	3724.0	38.00	0.33	5696	10	JRF/K-300	12.8
JL-5541F310-1003	3	2.3	0.045	1.9	0.08	338.3	3.45	1944.0	19.82	0.269	1003	10	JRF/K-310	18.1

Packing Details

QTY: 80 pcs/ctn Carton Size: 40.5*28*25 cm Gross Weight: .10.5 kg/ctn Net Weight: 10 kg/ctn



Typical Applications

- Household Appliances: Electric curtain, Intergrated cooker, Coffee maker, Intelligent closetool, Sweeping robot, Dish-washing
- Machine, Cooker hood, Electric lock.
- Hair Care: Hair Curler, Massager, Electric Hair Clipper
- Office Equipment: Shredder, Printer, Projector, Counting Machine
- Medical Equipment: Massage chair, Electric trolley, Medical pump, Electric bed, Electric wheelchair
- Industrial Equipment: Water, electrical and gas valve, Air switch, Pump, Automatic door, Automatic lubrication equipment.
- Business Equipment: Vending machines, Parking locks, ATM machines, Stage lights.
- Intelligent Robot: Mechanical Arm, UAV (Unmanned Aerial Vehicle), Service Robot

Outline Dimension

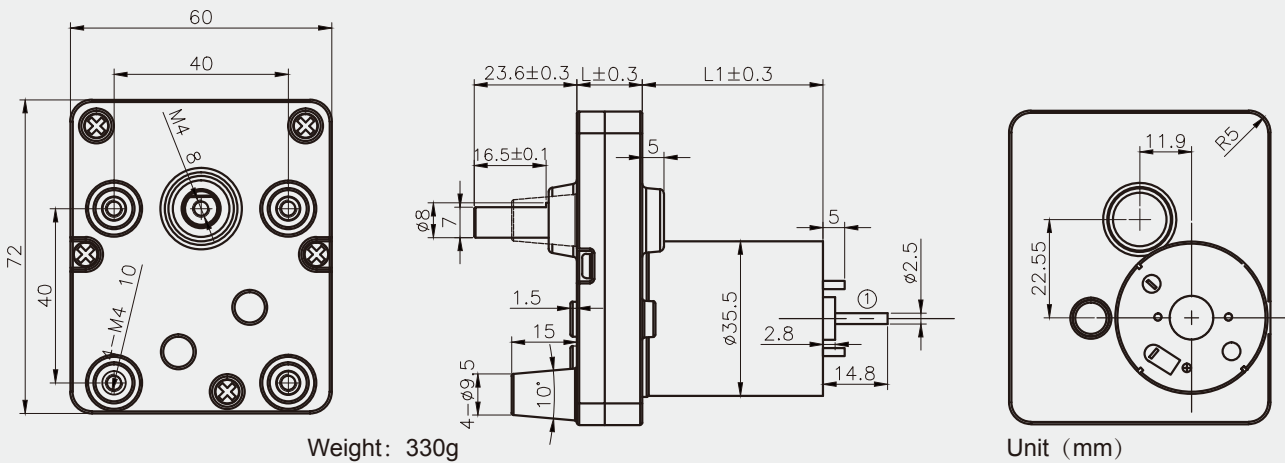

Voltage, rated torque, speed, current, power and shaft size can be customized as requirement.

Technical Data

MODEL	VOLTAGE	NO-LOAD		AT MAXIMUM EFFICIENCY				STALL TORQUE			GEAR RATIO	LENGTH OF GEAR BOX (L)	MATCH THE MOTOR	LENGTH OF MOTOR (L1)
		SPEED	CURRENT	SPEED	CURRENT	TORQUE		TORQUE	CURRENT					
		r/min	A	r/min	A	mN.m	Kg.cm	mN.m	Kg.cm	A				
V	r/min	A	r/min	A	mN.m	Kg.cm	mN.m	Kg.cm	A	mm		mm		
JL-6072F3540-35.8	24	140	0.12	114	0.45	537.3	5.48	2192.5	22.36	2	35.8	15	JRK-3540	40

Packing Details

TY: 48 pcs/ctn Carton Size: 36.5*26.5*25 cm Gross Weight: 17 kg/ctn Net Weight: 16 kg/ctn



Typical Applications

- Household Appliances: Electric curtain, Intergrated cooker, Coffee maker, Intelligent closetool, Sweeping robot, Dish-washing
- Machine, Cooker hood, Electric lock.
- Hair Care: Hair Curler, Massager, Electric Hair Clipper
- Office Equipment: Shredder, Printer, Projector, Counting Machine
- Medical Equipment: Massage chair, Electric trolley, Medical pump, Electric bed, Electric wheelchair
- Industrial Equipment: Water, electrical and gas valve, Air switch, Pump, Automatic door, Automatic lubrication equipment.
- Business Equipment: Vending machines, Parking locks, ATM machines, Stage lights.
- Intelligent Robot: Mechanical Arm, UAV (Unmanned Aerial Vehicle), Service Robot

Outline Dimension

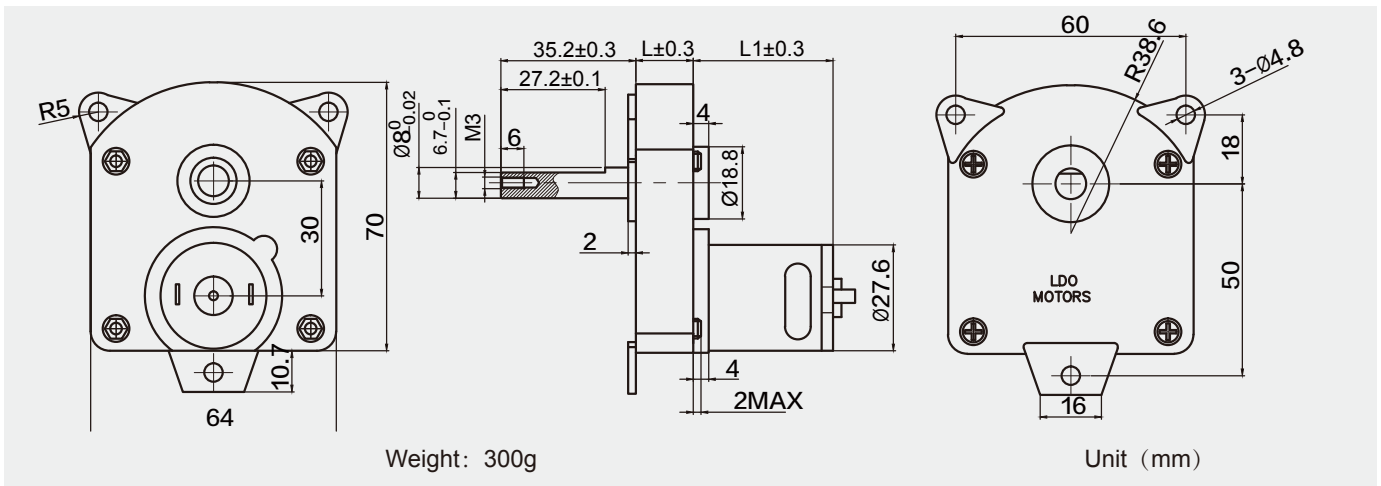

Voltage, rated torque, speed, current, power and shaft size can be customized as requirement.

Technical Data

MODEL	VOLTAGE	NO-LOAD		AT MAXIMUM EFFICIENCY			STALL TORQUE			GEAR RATIO	LENGTH OF GEAR BOX (L)	MATCH THE MOTOR	LENGTH OF MOTOR (L1)	
		SPEED	CURRENT	SPEED	CURRENT	TORQUE	TORQUE	CURRENT						
	V	r/min	A	r/min	A	mN.m	Kg.cm	mN.m	Kg.cm					A
JL-6470F365-52	24	110	0.06	79	0.15	169.7	1.73	604.5	6.16	0.39	52	15	JRK-365	32.6

Packing Details

QTY: 72 pcs/ctn Carton Size: 40.5*28*25 cm Gross Weight: 21 kg/ctn Net Weight: 20 kg/ctn