

直流无刷电机 DC BRUSHLESS MOTOR

JRB-190

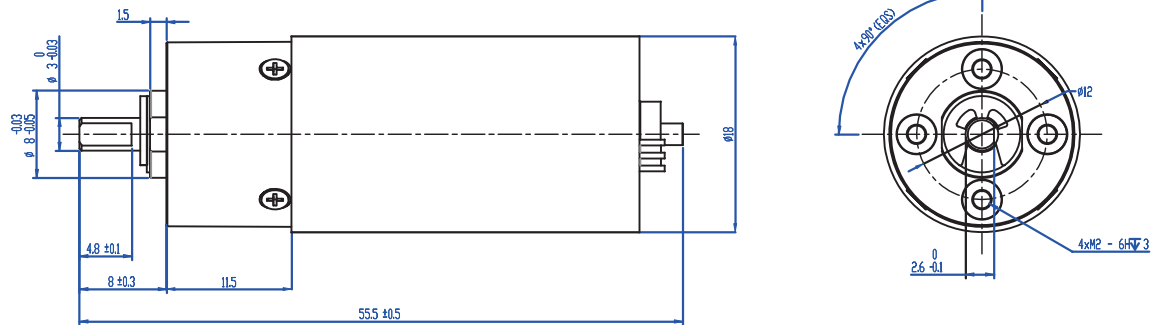

外形图 (单位 mm) Dimensions(Unit mm)



电压, 扭矩, 转速, 电流, 功率, 轴的尺寸可以按照客户需求定制。
 Voltage, Rated torque, Speed, Current, Power and Shaft size can be customized as requirement.

技术数据 Technical Data

型号 MODEL	电压 (V) VOLTAGE(V)		空载 NO-LOAD		最大效率点 AT MAXIMUM EFFICIENCY				堵转 STALL			
	使用范围 OPERATING RANGE	额定值 NOMINAL	转速 SPEED	电流 CURRENT	转速 SPEED	电流 CURRENT	转矩 TORQUE		功率 OUTPUT	转矩 TORQUE	电流 CURRENT	
			r/min	A	r/min	A	mN.m	g.cm	W	mN.m	g.cm	A
JRB-190-022020P4	4V-6V	5V	6550	80	6500	1.3	-	-	-	-	-	-

特性图 Characteristics

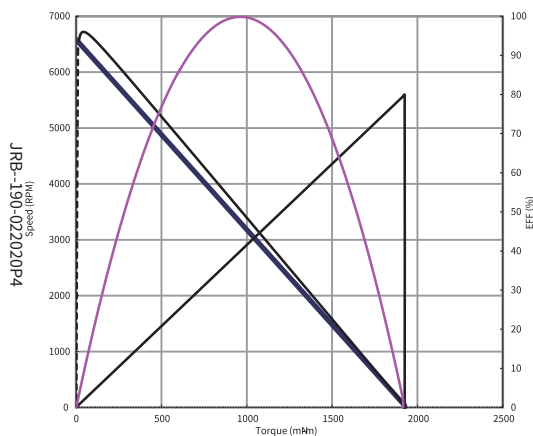

装箱信息 Packing Details

数量: 400 pcs/ctn 纸箱尺寸: 36.5*26.5*24 cm 毛重: 13 kg/ctn 净重: 12 kg/ctn 单重: 30 g
 QTY: 400 pcs/ctn Carton Size: 36.5*26.5*24 cm Gross Weight: 13 kg/ctn Net Weight: 12 kg/ctn Unit Weight :30 g



典型应用

- 家用电器: 电动窗帘, 集成灶, 咖啡机, 智能马桶, 扫地机器人, 洗碗机, 油烟机, 智能门锁
- 个人护理: 卷发器, 按摩仪器, 电动理发器
- 办公设备: 碎纸机, 打印机, 投影仪, 数钞机, 数币机
- 医疗设备: 按摩椅, 电动推车, 医疗泵, 电动床, 电动轮椅
- 工业设备: 水电气阀门, 空气开关, 泵, 自动门开关, 自动阅卷设备
- 商业设备: 自动售货机, 车位锁, ATM机, 智能灯具
- 机器人: 机械手, 无人机, 服务机器人

外形尺寸

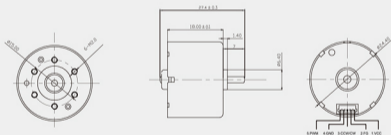

单重: 28g

单位 (mm)

电压, 扭矩, 转速, 电流, 功率, 输出轴的尺寸可以按照客户需求定制。

技术数据

型号	电压		空载		负载				启动			
	使用范围	额定值	转速	电流	转速	电流	扭矩	功率	转速	电流		
			r/min	A	r/min	A	mN.m	g.cm	W	mN.m	g.cm	A
JRB-310D-015097P0	5-15V	DC12V	6000	0.09	4800	0.20	2.5	25.5	1.21	9.8	100.0	0.70
JRB-310D-0131509P0	5-15V	DC9V	3100	0.06	2300	0.12	3.7	38.0	0.29	11.4	116.3	0.40
JRB-310D-017095P0	5-24V	DC24V	12500	0.12	10000	0.30	16.5	165.0	7.20	33.0	330.0	0.70
JRB-310D-0121609P0	5-24V	DC24V	7400	0.60	5920	0.16	3.0	30.8	1.99	14.5	148.0	0.66
JRB-310D-019066P0	3-6V	DC3.5V	2500	0.70	2090	0.14	1.7	17.4	0.28	4.9	50.0	0.55

装箱信息

数量: 400 pcs/ctn 纸箱尺寸: 36.5*26.5*24 cm 毛重: 11.5kg/ctn 净重: 10.5 kg/ctn



Typical Applications

- Household Appliances: Air freshener, Smart vacuum cleaner, Soap dispenser, Dryer.
- Hair Care: Hair dryer, Electric hair clipper, massage instrument.
- Office Equipment: Printer, Projector, Counting Machine, Shredder.
- Industrial Equipment: Water, electrical and gas valve, Air switch, Water ump, Air pump, Electric drill.
- Business Equipment: Vending machines, Parking locks, ATM machines, Mahjong machine, Card picking machine.

Outline Dimension

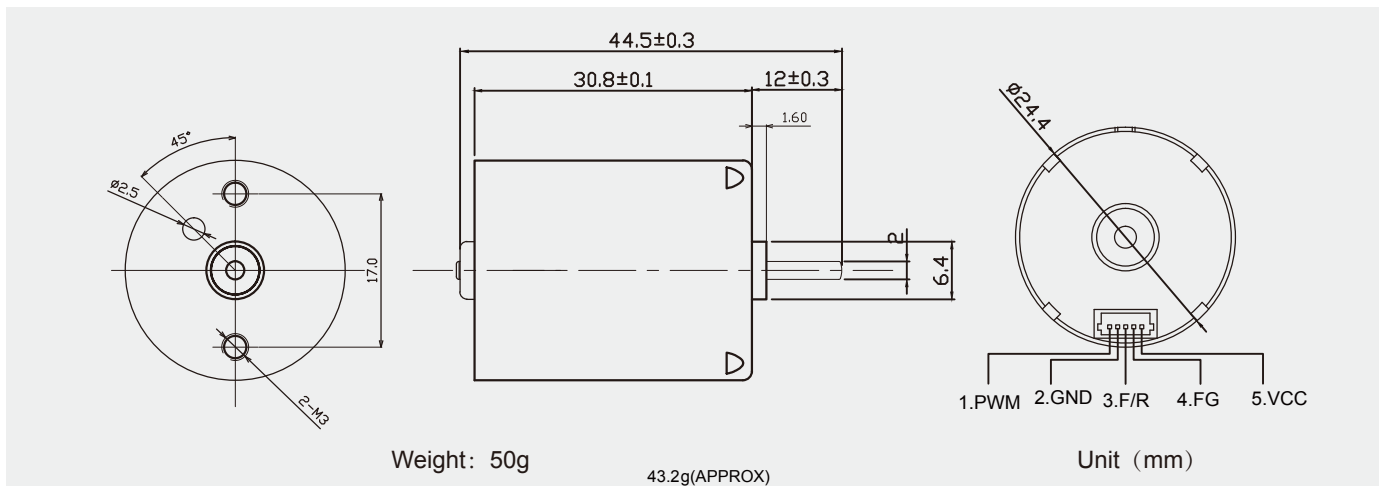

Voltage, rated torque, speed, current, power and shaft size can be customized as requirement.

Technical Data

MODEL	VOLTAGE		NO-LOAD		AT MAXIMUM EFFICIENCY					STALL		
	OPERATING RANGE	NOMINAL	SPEED	CURRENT	SPEED	CURRENT	TORQUE		OUTPUT	TORQUE		CURRENT
			r/min	A	r/min	A	mN.m	g.cm	W	mN.m	g.cm	A
JRB-370D-020049P0	3-6V	DC5V	3000	0.09	2400	0.325	3.0	30.1	0.66	24.5	250.0	0.60
JRB-370D-017083P0	8-24V	DC24V	8500	0.10	6800	0.30	6.5	65.8	3.05	32.7	333.3	0.60
JRB-370D-015096P0	8-24V	DC24V	7300	0.08	5800	0.25	6.0	61.0	2.53	23.9	243.3	0.70
JRB-370D-023047P0	8-24V	DC12V	7100	0.12	5600	0.40	5.1	52.4	2.68	23.2	236.6	0.60

Packing Details

QTY: 250 pcs/ctn Carton Size: 36.5*26.5*24 cm Gross Weight: 12 .5kg/ctn Net Weight: 11.5 kg/ctn



Typical Applications

- Household Appliances: Air freshener, Smart vacuum cleaner, Soap dispenser, Dryer.
- Hair Care: Hair dryer, Electric hair clipper, massage instrument.
- Office Equipment: Printer, Projector, Counting Machine, Shredder.
- Industrial Equipment: Water, electrical and gas valve, Air switch, Water ump, Air pump, Electric drill.
- Business Equipment: Vending machines, Parking locks, ATM machines, Mahjong machine, Card picking machine.

Outline Dimension

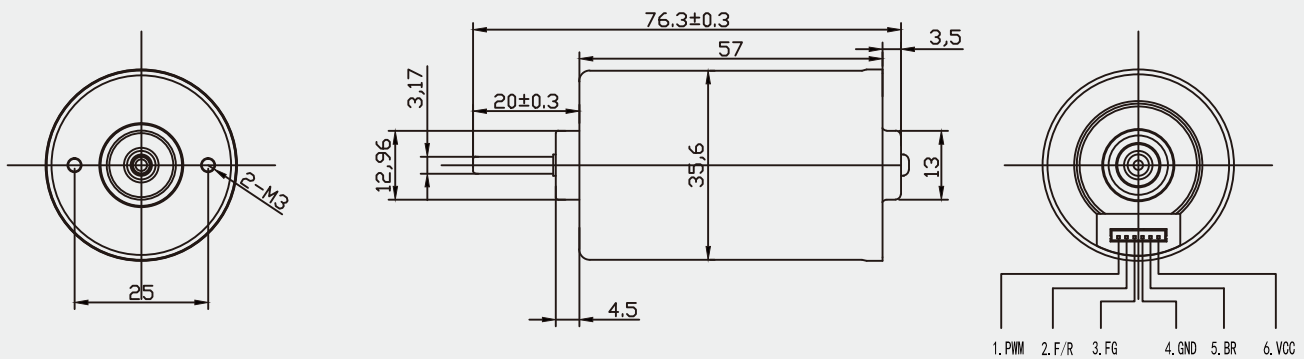

Weight: 220g

Unit (mm)

Voltage, rated torque, speed, current, power and shaft size can be customized as requirement.

Technical Data

MODEL	VOLTAGE		NO- LOAD		AT MAXIMUM EFFICIENCY					STALL		
	OPERATING RANGE	NOMINAL	SPEED	CURRENT	SPEED	CURRENT	TORQUE		OUTPUT	TORQUE		CURRENT
			r/min	A	r/min	A	mN.m	g.cm	W	mN.m	g.cm	A
JRB-555D-033025P0	8-15V	DC12V	3200	0.19	2500	0.90	17.5	178.2	11.36	89.7	920.0	3.50
JRB-555D-040015P0	8-15V	DC12V	6500	0.40	5200	1.30	20.2	205.8	20.17	98.1	1000.0	3.50
JRB-555D-041035P0	12-24V	DC24V	3900	0.20	3100	1.10	48.6	495.6	13.40	382.7	3900.0	4.00
JRB-555D-050023P0	12-24V	DC24V	4500	0.30	3600	1.50	19.3	195.6	19.60	294.0	3000.0	3.90
JRB-555D-018110P0	12-24V	DC24V	2200	0.10	1760	0.30	21.3	216.7	3.02	83.4	850.0	3.50

Packing Details

QTY: 60 pcs/ctn Carton Size: 39*30.5*17 cm Gross Weight: 13 kg/ctn Net Weight: 12 kg/ctn

直流无刷电机 DC BRUSHLESS MOTOR

JRB-775D



外形图 (单位 mm) Dimensions(Unit mm)

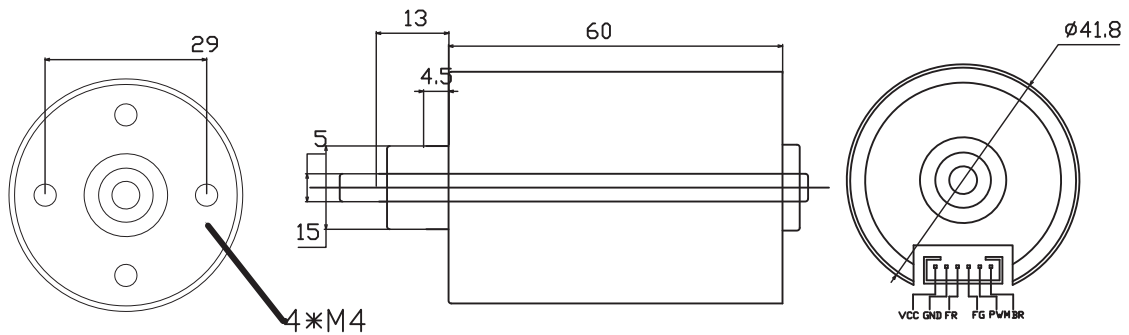

电压, 扭矩, 转速, 电流, 功率, 轴的尺寸可以按照客户需求定制。
 Voltage, Rated torque, Speed, Current, Power and Shaft size can be customized as requirement.

技术数据 Technical Data

型号 MODEL	电压 (V) VOLTAGE(V)		空载 NO-LOAD		最大效率点 AT MAXIMUM EFFICIENCY				堵转 STALL			
	使用范围 OPERATING RANGE	额定值 NOMINAL	转速 SPEED	电流 CURRENT	转速 SPEED	电流 CURRENT	转矩 TORQUE		功率 OUTPUT	转矩 TORQUE		电流 CURRENT
			r/min	A	r/min	A	mN.m	g.cm	W	mN.m	g.cm	A
JRB-775D-050043P6	8V~24V	24V	5000	0.21	4500	0.86	333.54	3400	20.64	196.20	2000	3.0
JRB-775D-069018P5	8V~24V	24V	12000	0.65	10300	2.30	294.30	3000	55.20	186.39	1900	3.1
JRB-775D-069018P5	6V~28V	28V	14600	0.63	13000	2.50	313.92	3200	70.00	196.20	2000	4.7
JRB-775D-050040P0	5V~24V	12V	2600	0.15	2300	0.85	245.25	2500	10.20	166.77	1700	2.0
JRB-775D-069020P0	6V~24V	24V	16000	0.55	15000	1.20	66.71	680	28.80	49.05	500	2.7

特性图 Characteristics

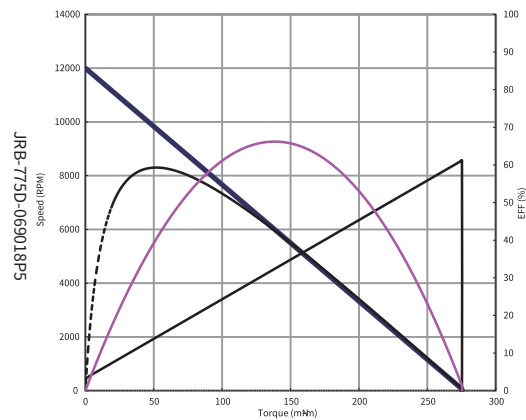
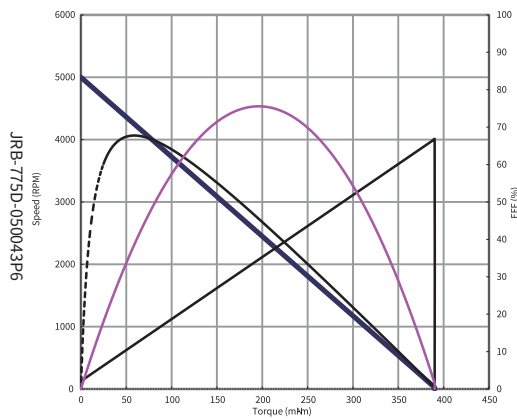

装箱信息 Packing Details

数量: 140 pcs/ctn 纸箱尺寸: 36*25*23 cm 毛重: 15.60 kg/ctn 净重: 15.12 kg/ctn 单重: 108 g
 QTY: 140 pcs/ctn Carton Size: 36*25*23 cm Gross Weight: 15.60 kg/ctn Net Weight: 15.12 kg/ctn Unit Weight :108 g

直流无刷电机 DC BRUSHLESS MOTOR

JRB-2838D



外形图 (单位 mm) Dimensions(Unit mm)

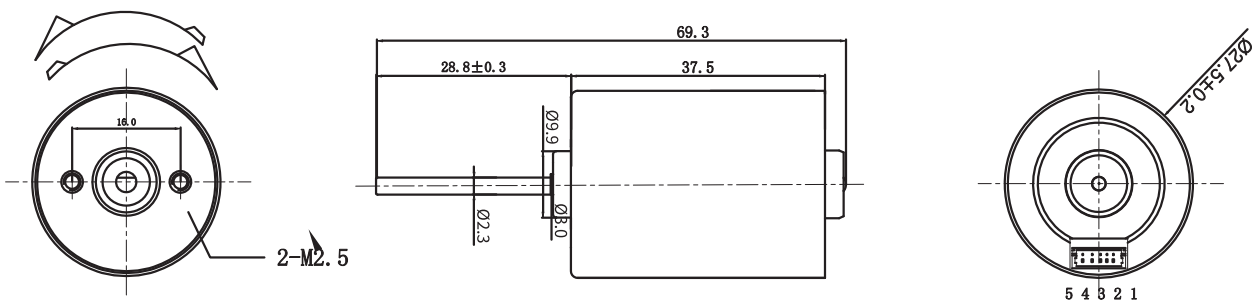

电压, 扭矩, 转速, 电流, 功率, 轴的尺寸可以按照客户需求定制。
 Voltage, Rated torque, Speed, Current, Power and Shaft size can be customized as requirement.

技术数据 Technical Data

型号 MODEL	电压 (V) VOLTAGE(V)		空载 NO-LOAD		最大效率点 AT MAXIMUM EFFICIENCY				堵转 STALL			
	使用范围 OPERATING RANGE	额定值 NOMINAL	转速 SPEED	电流 CURRENT	转速 SPEED	电流 CURRENT	转矩 TORQUE		功率 OUTPUT	转矩 TORQUE		电流 CURRENT
			r/min	A	r/min	A	mN.m	g.cm	W	mN.m	g.cm	A
JRB-2838D-025048P0	5V~24V	24V	7000	0.12	5800	0.32	61.80	630	7.68	54.94	560	0.80
JRB-2838D-033034P0	5V~18V	15V	9600	0.10	8000	0.38	34.34	350	5.70	27.47	280	1.30
JRB-2838D-033027P0	5V~15V	12V	6300	0.13	4800	0.74	63.77	650	8.88	57.88	590	2.30
JRB-2838D-033034P0	5V~24V	12V	3800	0.10	3200	0.50	83.39	850	6.00	75.54	770	2.70
JRB-2838D-031028P0	5V~24V	12V	8200	0.12	6500	0.50	29.43	300	6.00	23.54	240	0.78

特性图 Characteristics

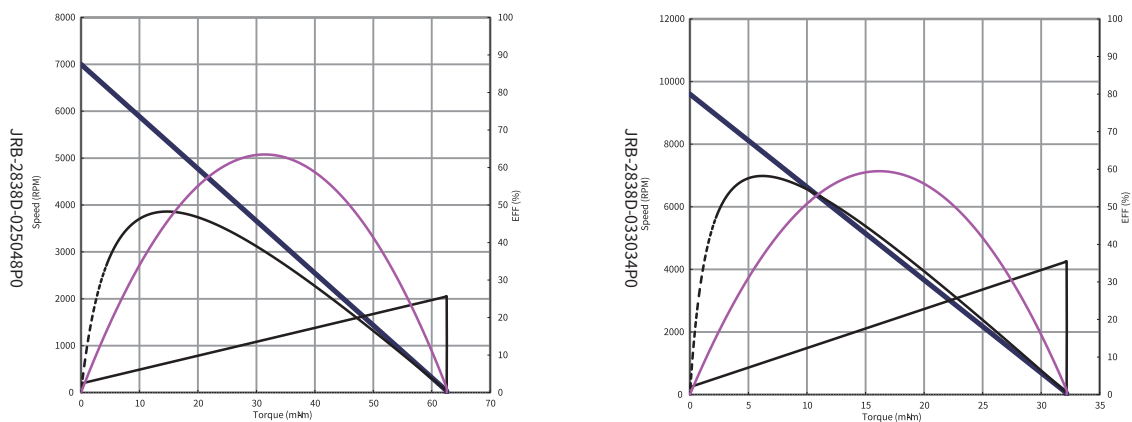

装箱信息 Packing Details

数量: 60 pcs/ctn 纸箱尺寸: 9*30.50*17 cm 毛重: 10 kg/ctn 净重: 9.42 kg/ctn 单重: 157 g
 QTY: 60 pcs/ctn Carton Size: 9*30.50*17 cm Gross Weight: 10 kg/ctn Net Weight: 9.42 kg/ctn Unit Weight: 157 g



外形图 (单位 mm) Dimensions (Unit mm)

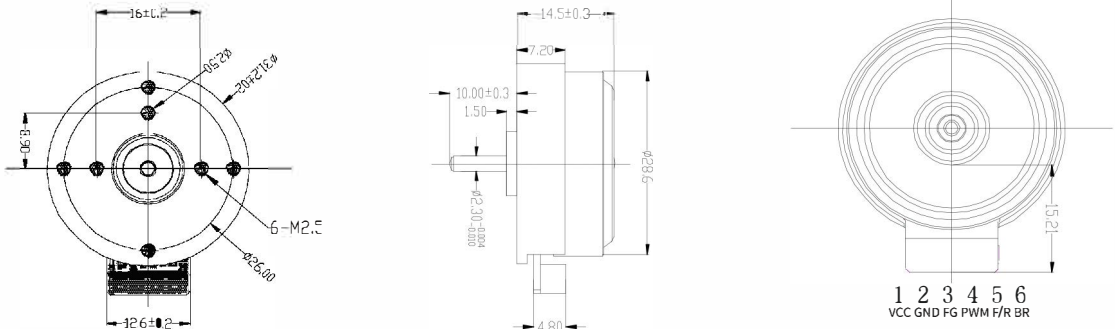

电压, 扭矩, 转速, 电流, 功率, 轴的尺寸可以按照客户需求定制。
Voltage, Rated torque, Speed, Current, Power and Shaft size can be customized as requirement.

技术数据 Technical Data

型号 MODEL	电压 (V) VOLTAGE (V)		空载 NO-LOAD		最大效率点 AT MAXIMUM EFFICIENCY				堵转 STALL			
	使用范围 OPERATING RANGE	额定值 NOMINAL	转速 SPEED	电流 CURRENT	转速 SPEED	电流 CURRENT	转矩 TORQUE		功率 OUTPUT	转矩 TORQUE		电流 CURRENT
			r/min	A	r/min	A	mN.m	g.cm	W	mN.m	g.cm	A
JRB-3012-019062-P6	5-12	12	6700	0.11	5300	0.3	24.53	250	3.6	16.68	170	0.55

特性图 Characteristics

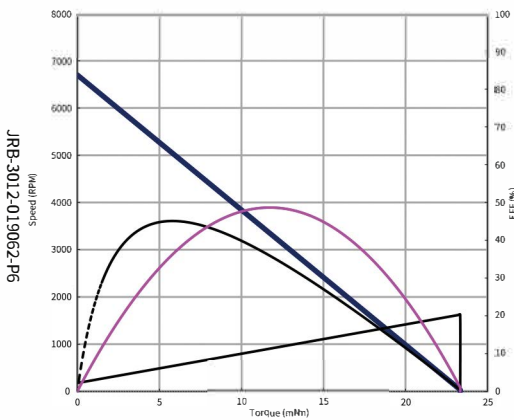

装箱信息 Packing Details

数量: 500 pcs/ctn 纸箱尺寸: 36.5*26*22.5 cm 毛重: 11.50 kg/ctn 净重: 11 kg/ctn 单重: 22 g
QTY: 500 pcs/ctn Carton Size: 36.5*26*22.5 cm Gross Weight: 11.50 kg/ctn Net Weight: 11 kg/ctn Unit Weight: 22 g

直流无刷电机 DC BRUSHLESS MOTOR

JRB-3412



外形图 (单位 mm) Dimensions (Unit mm)

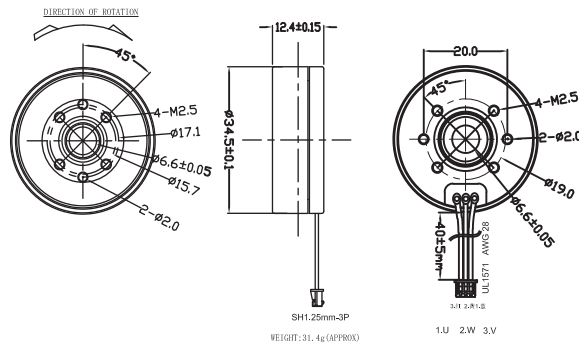

电压, 扭矩, 转速, 电流, 功率, 轴的尺寸可以按照客户需求定制。
 Voltage, Rated torque, Speed, Current, Power and Shaft size can be customized as requirement.

技术数据 Technical Data

型号 MODEL	电压 (V) VOLTAGE (V)		空载 NO-LOAD		最大效率点 AT MAXIMUM EFFICIENCY				堵转 STALL			
	使用范围 OPERATING RANGE	额定值 NOMINAL	转速 SPEED	电流 CURRENT	转速 SPEED	电流 CURRENT	转矩 TORQUE		功率 OUTPUT	转矩 TORQUE		电流 CURRENT
			r/min	A	r/min	A	mN.m	g.cm	W	mN.m	g.cm	A
JRB-3412-016122P3	4-6	5	380	0.02	310	0.028	2.45	25	0.1	1.96	20	0.06

特性图 Characteristics

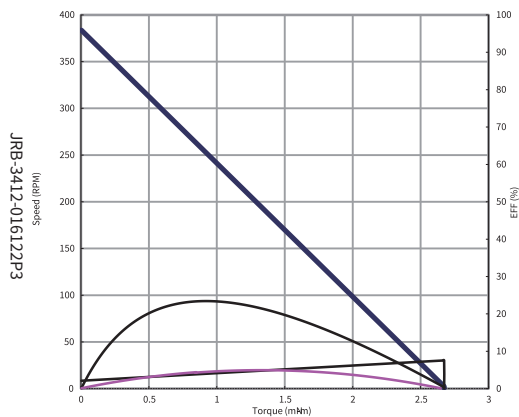

装箱信息 Packing Details

数量: 500 pcs/ctn 纸箱尺寸: 36.5*26*22.5 cm 毛重: 16.50 kg/ctn 净重: 15.80 kg/ctn 单重: 31.59 g
 QTY: 500 pcs/ctn Carton Size: 36.5*26*22.5 cm Gross Weight: 16.50 kg/ctn Net Weight: 15.80 kg/ctn Unit Weight: 31.59 g



典型应用

- 家用电器：电动窗帘，集成灶，咖啡机，智能马桶，扫地机器人，洗碗机，油烟机，智能门锁
- 个人护理：卷发器，按摩仪器，电动理发器
- 办公设备：碎纸机，打印机，投影仪，数钞机，数币机
- 医疗设备：按摩椅，电动推床，医疗泵，电动床，电动轮椅
- 工业设备：水电气阀门，空气开关，泵，自动门开关，自动润滑设备
- 商业设备：自动贩卖机，车位锁，ATM机，智能灯具
- 机器人：机械手，无人机，服务机器人

外形尺寸

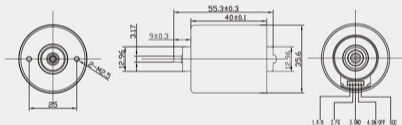

单重：140g

单位：(mm)

电压，扭矩，转速，电流，功率，输出轴的尺寸可以按照客户需求定制。

技术数据

型号	电压		空载		负载				启动			
	使用范围	额定值	转速	电流	转速	电流	扭矩	功率	扭矩		电流	
			r/min	A	r/min	A	mN.m	g.cm	W	mN.m	g.cm	A
JRB-35400-01810P0	8-24V	DC24V	2200	0.10	1799	0.90	11.3	114.6	5.47	83.5	850.0	3.50
JRB-35400-045014P0	8-24V	DC12V	7200	0.50	5760	1.38	21.4	218.0	12.54	220.0	1908.4	3.80
JRB-35400-031035P0	8-24V	DC12V	4500	0.19	3600	0.55	13.2	134.4	3.38	53.9	549.2	3.50
JRB-35400-028035P0	8-24V	DC24V	9500	0.25	7600	0.80	13.7	139.8	10.80	68.6	699.0	3.50
JRB-35400-028026P0	8-24V	DC12V	6000	0.23	4770	0.65	9.5	96.9	6.60	52.6	535.8	3.50

装箱信息

数量：80 pcs/ctn 纸箱尺寸：40.5*28*25 cm 毛重：12 kg/ctn 净重：11 kg/ctn

直流无刷电机

产品名称：直流无刷电机

型号：JL-3630

直径：36mm

长度：41mm

电压：6V, 12V, 24V等, 可定制

转速：2000, 5000, 10000等, 可定制

产品认证：ISO9001, ROHS, CE等



自主研发, 自开模

研发实力



定转子为纯铜绕线, 导电性强, 电阻小

纯铜线马达

耐磨, 性能高, 小体积, 大力矩

金属齿轮



技术数据

Technical Data

型号 MODEL	电压 (V) VOLTAGE(V)		空载 NO-LOAD		最大效率点 AT MAXIMUM EFFICIENCY				堵转 STALL			
	使用范围 OPERATING RANGE	额定值 NOMINAL	转速 SPEED	电流 CURRENT	转速 SPEED	电流 CURRENT	转矩 TORQUE		功率 OUTPUT	转矩 TORQUE		电流 CURRENT
			r/min	A	r/min	A	mN.m	g.cm	W	mN.m	g.cm	A
JRB-3630-034060P3	5V-15V	12V	7200	0.3	6500	0.55	44.15	450	6.6	34.335	350	0.6
JRB-3630-038054P2	5V-15V	12V	7000	0.16	6200	0.5	58.86	600	6	49.05	500	0.6

电压, 扭矩, 转速, 电流, 功率, 输出轴的尺寸可以按照客户需求定制。

外形尺寸

Outline Dimension

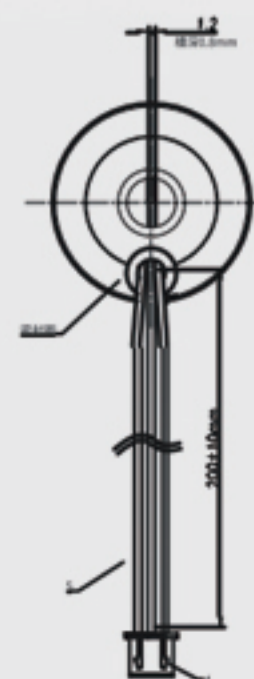
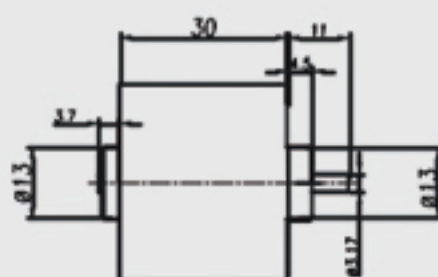
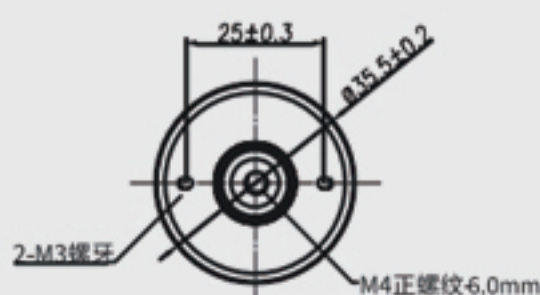

线材连接器端口极性/规格
 1.红色: 电源正极 (VCC)
 2.黑色: 电子源负极 (GND)
 3.蓝色: 正反转
 3.连接器型号: XH2.5-2P
 4.线材: UL1007 26AWG 红黑蓝
 L=200mm

直流无刷电机

产品名称：直流无刷电机

型号：JL-3640D

直径：36mm

长度：60mm

电压：6V, 12V, 24V等, 可定制

转速：2000, 5000, 10000等, 可定制

产品认证：ISO9001, ROHS, CE等



自主研发, 自开模

研发实力



定转子为纯铜绕线, 导电性强, 电阻小

纯铜线马达



耐磨, 性能高, 小体积, 大力矩

金属齿轮



技术数据

Technical Data

型号 MODEL	电压 (V) VOLTAGE(V)		空载 NO-LOAD		最大效率点 AT MAXIMUM EFFICIENCY				堵转 STALL			
	使用范围 OPERATING RANGE	额定值 NOMINAL	转速 SPEED	电流 CURRENT	转速 SPEED	电流 CURRENT	转矩 TORQUE		功率 OUTPUT	转矩 TORQUE		电流 CURRENT
			r/min	A	r/min	A	mN.m	g.cm	W	mN.m	g.cm	A
JRB-3640D-024045P0	6V-24V	24V	5000	0.15	4000	0.53	107.91	1100	12.72	78.48	800	2.9
JRB-3640D-045017P0	6V-15V	12V	6000	0.38	5100	1.30	117.72	1200	15.6	78.48	800	2.7
JRB-3640D-038023P0	6V-24V	15V	5700	0.23	4600	1.20	147.15	1500	18	117.72	1200	1.2
JRB-3640D-024065P0	6V-24V	24V	3300	0.12	2500	0.50	122.63	1250	12	98.10	1000	1.3
JRB-3640D-033034P0	6V-24V	12V	3200	0.17	2600	0.56	107.91	1100	6.72	68.67	700	2.7

电压, 扭矩, 转速, 电流, 功率, 输出轴的尺寸可以按照客户需求定制。

外形尺寸

Outline Dimension

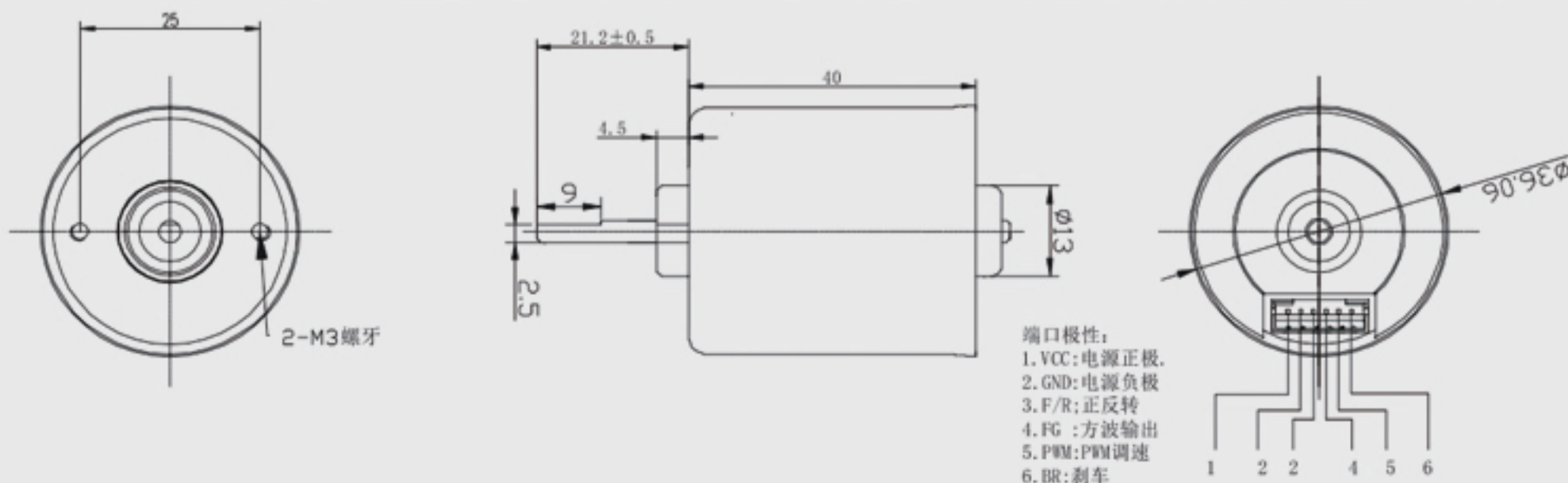

直流无刷电机

产品名称：直流无刷电机

型号：JL-4286

直径：42mm

长度：170mm

电压：6V, 12V, 24V等, 可定制

转速：2000, 5000, 10000等, 可定制

产品认证：ISO9001, ROHS, CE等

自主研发，自开模

研发实力

定转子为纯铜绕线，导电性强，电阻小

纯铜线马达

耐磨，性能高，小体积，大力矩

金属齿轮

技术数据

Technical Data

型号 MODEL	电压 (V) VOLTAGE(V)		空载 NO-LOAD		最大效率点 AT MAXIMUM EFFICIENCY				堵转 STALL			
	使用范围 OPERATING RANGE	额定值 NOMINAL	转速 SPEED	电流 CURRENT	转速 SPEED	电流 CURRENT	转矩 TORQUE		功率 OUTPUT	转矩 TORQUE		电流 CURRENT
			r/min	A	r/min	A	mN.m	g.cm	W	mN.m	g.cm	A
JRB-4286-045038P3	5V-18V	16.8V	6200	0.23	5059	1.02	60.62	600	10.28	23.81	550	1.03
JRB-4286-069022P3	5V-18V	14.4V	6600	0.5	5860	1.5	63.77	650	21.6	49.05	500	1.3

电压，扭矩，转速，电流，功率，输出轴的尺寸可以按照客户需求定制。

外形尺寸

Outline Dimension

