

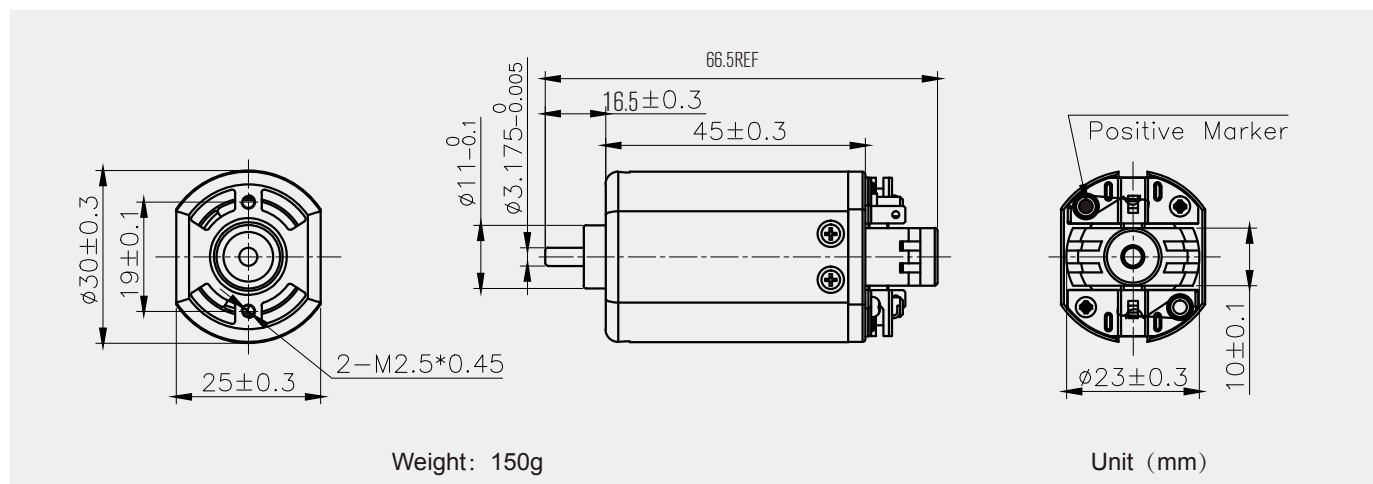

Typical Applications

- Household Appliances: Air freshener, Smart vacuum cleaner, Soap dispenser, Dryer.
- Hair Care: Hair dryer, Electric hair clipper, massage instrument.
- Office Equipment: Printer, Projector, Counting Machine, Shredder.
- Industrial Equipment: Water, electrical and gas valve, Air switch, Water ump, Air pump, Electric drill.
- Business Equipment: Vending machines, Parking locks, ATM machines, Mahjong machine, Card picking machine.

Outline Dimension



Voltage, rated torque, speed, current, power and shaft size can be customized as requirement.

Technical Data

MODEL	VOLTAGE(V)		NO-LOAD		AT MAXIMUM EFFICIENCY				STALL			
	OPERATING RANGE	NOMINAL	SPEED	CURRENT	SPEED	CURRENT	TORQUE		OUTPUT	TORQUE		CURRENT
			r/min	A	r/min	A	mN.m	g.cm	W	mN.m	g.cm	A
JFK-3045-016083	6~12	8.4V CONSTANT	27000	3.00	21800	11.80	74.5	760.0	169.93	392.3	4000.0	50.0
JFK-3045-011100	6~12	8.4V CONSTANT	42000	4.00	33560	15.10	49.0	500.0	172.10	245.2	2500.0	60.0

Packing Details

QTY: 80 pcs/ctn Carton Size: 40.5*28*25 cm Gross Weight: 13 kg/ctn Net Weight: 12 kg/ctn



Typical Applications

- Household Appliances: Air freshener, Smart vacuum cleaner, Soap dispenser, Dryer.
- Hair Care: Hair dryer, Electric hair clipper, massage instrument.
- Office Equipment: Printer, Projector, Counting Machine, Shredder.
- Industrial Equipment: Water, electrical and gas valve, Air switch, Water ump, Air pump, Electric drill.
- Business Equipment: Vending machines, Parking locks, ATM machines, Mahjong machine, Card picking machine.

Outline Dimension

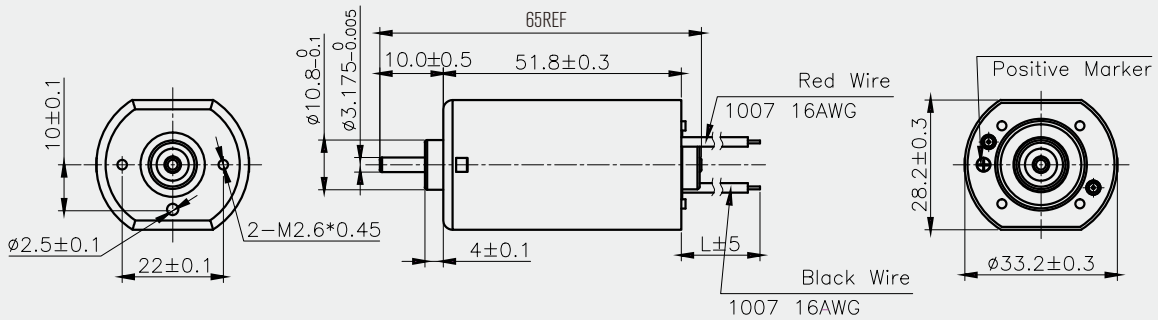

Weight: 160g

Unit (mm)

Voltage, rated torque, speed, current, power and shaft size can be customized as requirement.

Technical Data

MODEL	VOLTAGE(V)		NO-LOAD		AT MAXIMUM EFFICIENCY					STALL		
	OPERATING RANGE	NOMINAL	SPEED	CURRENT	SPEED	CURRENT	TORQUE		OUTPUT	TORQUE		CURRENT
			r/min	A	r/min	A	mN.m	g.cm	W	mN.m	g.cm	A
JFK-5508-044028	1.5~9	5.5V CONSTANT	2300	0.30	1759	0.97	13.3	135.1	2.44	56.4	574.6	3.18
JFK-5508-112018	3~18	12V CONSTANT	2000	0.07	1549	0.24	9.8	100.2	1.59	43.6	444.2	0.83
JFK-5508-059025	3~24	18V CONSTANT	6000	0.12	5081	0.66	16.4	167.0	8.70	106.9	1090.1	3.67
JFK-5508-093019	12~36	24V CONSTANT	5000	0.10	4137	0.48	16.9	172.3	7.31	98.0	999.3	2.30

Packing Details

QTY: 60 pcs/ctn Carton Size: 38*27.3*17 cm Gross Weight: 10 kg/ctn Net Weight: 9 kg/ctn



Typical Applications

- Household Appliances: Electric curtain, Intergrated cooker, Coffee maker, Intelligent closetool, Sweeping robot, Dish-washing Machine, Cooker hood, Electric lock.
- Hair Care: Hair Curler, Massager, Electric Hair Clipper
- Office Equipment: Shredder, Printer, Projector, Counting Machine
- Medical Equipment: Massage chair, Electric trolley, Medical pump, Electric bed, Electric wheelchair
- Industrial Equipment: Water, electrical and gas valve, Air switch, Pump, Automatic door, Automatic lubrication equipment.
- Business Equipment: Vending machines, Parking locks, ATM machines, Stage lights.
- Intelligent Robot: Mechanical Arm, UAV (Unmanned Aerial Vehicle), Service Robot

Outline Dimension

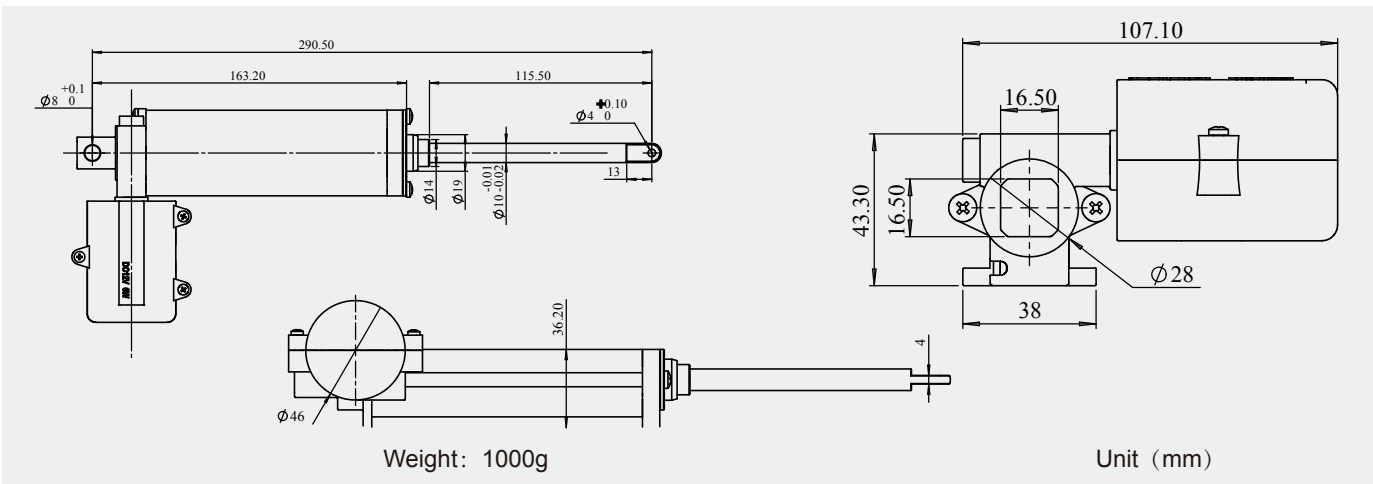

Voltage, rated torque, speed, current, power and shaft size can be customized as requirement.

Technical Data

DC LINEAR ACTUATOR MOTOR SPECIFICATION			
Working Voltage	DC 9-18V	Rated Voltage	DC 12V
No-load Speed	21±15%mm/s	No-load Current	0.1A max
Maximum Thrust (Motor Stall)	225±10%N	Stall Current	1.7A max
Rated Load	30N	Rated Current	0.55A max
Rated Speed	16±15%mm/s	Self-locking Force	100N min
Install the distance	290.5±1mm(adjustable)	Trip	90±1mm(adjustable)
Temperature	(-) 10-60°C	Humidity	20%-90%

Packing Details

QTY: 15pcs/ctn Carton Size: 36.5*26.5*24cm Gross Weight: 16 kg/ctn Net Weight: 15 kg/ctn

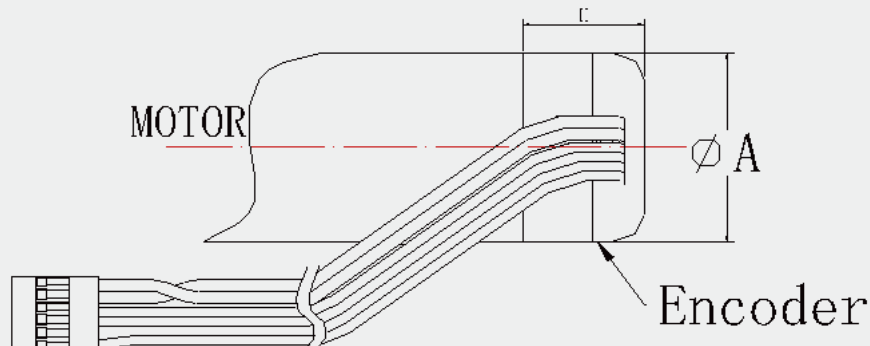

Typical Applications

- Two channels/Single channel Hall Encoder
- Size customized, different to choose from
- Consumption of current type digital output.
- High reflection frequency from 0Kz to 100KHz
- Temperature range $-40^{\circ}\text{C} \sim +125^{\circ}\text{C}$

Outline Dimension

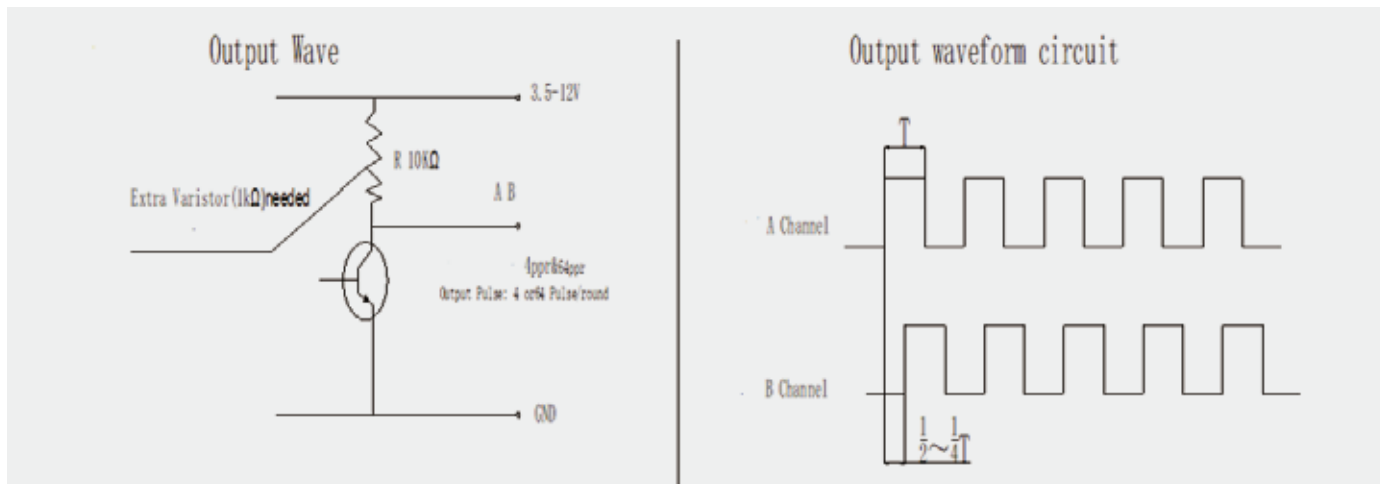

Voltage, rated torque, speed, current, power and shaft size can be customized as requirement.

Technical Data

Appearance.size(mm)

Dimensions		Appearance.size(mm)				
Motor Modie	EncoderΦA	EncoderH	Output Pulse	Wire Type Lengfh	Connector Type	Connections
JL-12FN20	Φ12	8	28ppr	UL1571 28AWG	PH2.0mm-6P	1.Red wire: motor+ 2.Black wire: motor- 3.Green wire: Hall sensor GND 4.Bule wire: Hall sensor VCC 5.Yellow wire: Hall sensor Avout 6.Whitewire: Hall sensor Avout Can be customized according to customer requirements.
JL-25A310/JL-32Z370	Φ24.1	15	8ppr	UL1007 26AWG	PH2.0mm-6P	
JL-37B365	Φ30	16.5	8ppr	UL1007 24AWG	PH2.0mm-6P	
JL-38F520	Φ33	12.5	28ppr 64ppR	UL1007 24AWG	PH2.0mm-6P	
JL-36P555/JL-37B555	Φ36.8	18	24PPR 28PPR 64PPR	UL1007 24AWG	XH2.5-6P	
JL-42P775	Φ40	18	64ppr	UL1007 24AWG+22AWG	XH2.5-6P	